



**Centre National d'Etudes  
Spatiales**

Réf. :TRO-0-ST-1610-CNES  
Ed.:3 : Date: Jan 17<sup>th</sup> 2013  
Rév.: 4



**Indian Space Research  
Organisation**

## « MEGHA-TROPIQUES »

### MEGHA-TROPIQUES Level 1 Products definition

	Name, title	date, signature
Prepared by	<b>Megha -Tropiques Team</b>	
Authorised By	<b>G Raju MEGHA- TROPIQUES Project Director</b>	
Authorised by	<b>N KARUCHE MEGHA- TROPIQUES Project manager</b>	

C.N.E.S./ I.S.R.O.	<b>Megha-Tropiques</b>	Réf. TRO-0-ST-1610-CNES Ed: 3 Date: Jan17th 2013 Issue : 4 Page : ii
--------------------	------------------------	---

<b>INDEX</b>
--------------

<b><u>CONFIDENTIALITY</u> :</b>		<b><u>Key words</u> :</b>	
<b><u>TITLE</u> : L1 product definition</b>			
<b><u>AUTHORS</u> :</b>			
<b><u>CNES : CNES team</u></b>		<b><u>ISRO : ISRO team</u></b>	
N karouche A Rosak C Goldstein J Rollin : AKKA B Picart : CLS E Hillairet: Magellium		1. Santanu Chowdhury 2. Dinesh Kumar Jain	
<b><u>SCOPE</u></b>			
<b><u>DOCUMENT</u> : L1 product definition</b>			
<b><u>Total Page</u></b>		<b><u>Annex</u> :</b>	
<b><u>Numbers: 65</u></b>		<b><u>LANGUAGE</u> :</b>	
<b><u>CONFIGURATION CONTROL</u> :</b>		<b><u>RESPONSIBLE</u>: N. Karouche</b>	
<b><u>Date</u> : 10/08/11</b>		<b>G. Raju</b>	
<b><u>SYSTEME HOTE</u> : PC - WORD 7</b>			

C.N.E.S./ I.S.R.O.	<b>Megha-Tropiques</b>	Réf. TRO-0-ST-1610-CNES Ed: 3      Date: Jan17th 2013 Issue : 4 Page : iii
--------------------	------------------------	---

**DISTRIBUTION**

<p><b><u>CNES</u></b></p> <p>N. Karouche  A. Rosak  C. Goldstein  A Liferman  J Rollin (AKKA)</p> <p><b><u>CLS</u></b></p> <p>B Picard</p> <p><b><u>Magellium</u></b></p> <p>E. Hillairet</p>	<p><b><u>ISRO</u></b></p> <p>Santanu Chowdhury  J. Dinesh  MT. Chamy  A. V. Khened</p>
---	--

**DOCUMENT CHANGE RECORD**

EDITION	ISSUE	DATE	CHANGE INFORMATION	VISA
1	0		<u>Initial release</u>	
1	1	12/01/10	CNES Modifications	
1	2	18/02/10	ISRO modifications	
1	3	12/04/10	CNES Modifications	
1	4	03/05/10	ISRO Modifications at §4.4.3.11 to §4.4.3.16 and §7	
1	5	20/05/10	CNES Modifications at §4.4.3.11 to §4.4.3.25 and §8, and table 3.1-7	
1	6	10/06/10	CNES corrections : on section 4.4.3.2 latitude/co latitude	
1	7	5/07/2010	ISRO modifications on flags section 4.4.3.11 to 4.4.4 17	
1	8	12/12/2010	CNES modifications on flags section 4.4.3.11 to 4.4.4 17 clarifications on conventions Sunglint angle definition Flags clarifications	
2	0	10feb2011	CNES modifications : ⇒ §2.1 Applicable documents ⇒ §3.1 Scan rate as per ISRO measurements ⇒ §.4.3.10 Datation of pixels ⇒ §4.4.3.14 sunt glint at Sample/pixel flag removed for Scarab ⇒ §4.4.3.14: interpolation quality flag added ⇒ 6.3.1MADRAS L1B generated from L1A2 ⇒ Minor corrections	
2	1	10/08/2011	CNES modifications : ⇒ § File naming convention, ⇒ § flags definition,	
2	2	26/09/2011	CNES modifications based on CNES/ISRO teleconf sept 20th  - Emergency mode to be removed - Clarification on TB validity - Minor corrections	
2	3	27/09/2011	- corrections on channel ON/OFF validity	

C.N.E.S./ I.S.R.O.	<h1>Megha-Tropiques</h1>	Réf. TRO-0-ST-1610-CNES Ed: 3 Date: Jan17th 2013 Issue : 4 Page : 5
--------------------	--------------------------	--

2	4	23/11/2011	Comments from ISRO/CNES meeting Nov 2011 and scarab update <ul style="list-style-type: none"> <li>• Gain flag on scarab</li> <li>• File naming : change on example</li> <li>• Lat/lon Nadir definition</li> <li>• Error on hot calibration zone</li> <li>• MADRAS Calibration flag and corrected scans</li> <li>• Datation in L1B product</li> <li>• Minor corrections</li> </ul>	
2	5	25/01/2012	<ul style="list-style-type: none"> <li>• Flag for tagging Madras corrections</li> </ul>	
2	6	21/02/2012	<ul style="list-style-type: none"> <li>• Flag for SCARAB : removal of space calibration error</li> <li>• Flag clarification</li> <li>• Flag “ degraded calibration averaging” instead of “default in gain averaging”</li> <li>• Ice flag clarification</li> <li>• Solar zenith angle : clarification</li> <li>• Minor corrections</li> </ul>	
2	7	2/03/2012	<ul style="list-style-type: none"> <li>• Quality flag MSB/LSB clarification</li> </ul>	
2	8	20/03/2012	<ul style="list-style-type: none"> <li>• Surface type : land/sea and land contamination</li> <li>• AOC/AGC flag change</li> </ul> Minor corrections quality flag	
2	9	11/04/2012	<ul style="list-style-type: none"> <li>• File name change for IODD parameter</li> </ul>	
3	0	07/07/2012	<ul style="list-style-type: none"> <li>• File naming convention update</li> <li>• Change in quality flag (minor corrections)</li> </ul>	CN_N°6
3	1	29/08/2012	<ul style="list-style-type: none"> <li>• Addition of 3 digits extension on SW Version number in file name convention</li> </ul> Minor corrections	CN_N°6Rev1
3	2	15/10/2012	<ul style="list-style-type: none"> <li>• Flags for MADRAS corrections</li> <li>• Flags for L1A3</li> <li>• File naming convention (corrections)</li> </ul> Minor corrections	CN_N°7
3	3	7/12/2012	<ul style="list-style-type: none"> <li>• Flags : minor corrections</li> <li>• Reprocessing version in orbit product</li> </ul>	(cancelled)

C.N.E.S./ I.S.R.O.	<b>Megha-Tropiques</b>	Réf. TRO-0-ST-1610-CNES Ed: 3 Date: Jan17th 2013 Issue : 4 Page : 6
--------------------	------------------------	--

3	4	17/01/2012	<p>Release consistent to software version V4000</p> <ul style="list-style-type: none"> <li>• information on MADRAS Flags</li> <li>• Removal of a identification of Reprocessing version in orbit product in file name</li> <li>• Excel sheet update 13rev2 to include L0 product name as general attribute</li> <li>• Madras valid samples : all samples are valid</li> <li>• Correction on hot/cold samples start and end values</li> </ul>	CN 5rev2
---	---	------------	--	----------

**PAGE STATUS LIST**

Page	Edition	Issues	Page	Edition	Issues
All	1	0			
All	1	1			
All	1	2			
All	1	3			
All	1	4			
All	1	5			
All	1	6			
All	1	7			
All	1	8			
All	1	9			
All	2	0			
All	2	1			
All	2	2			
All	2	3			
All	2	4			
All	2	5			
All	2	6			
All	2	7			
All	2	8			
All	2	9			
All	3	0			
All	3	1			
All	3	2			
All	3	3			
All	3	4			

TABLE OF CONTENTS

<b>1</b>	<b><i>Purpose</i></b> .....	<b>10</b>
<b>2</b>	<b><i>Reference and applicable documents</i></b> .....	<b>10</b>
2.1	<b>Applicable Documents</b> .....	<b>10</b>
2.2	<b>Reference Documents</b> .....	<b>11</b>
<b>3</b>	<b><i>Instruments general description</i></b> .....	<b>11</b>
3.1	<b>MADRAS instrument</b> .....	<b>11</b>
3.2	<b>SAPHIR Instrument</b> .....	<b>16</b>
3.3	<b>Scarab Instrument</b> .....	<b>19</b>
<b>4</b>	<b><i>Definition of L1 data product</i></b> .....	<b>21</b>
4.1	<b>Standard product</b> .....	<b>21</b>
4.2	<b>NRT products</b> .....	<b>21</b>
4.3	<b>General characteristics of paramters</b> .....	<b>22</b>
4.3.1	Satellite modes .....	22
4.3.2	Scanning Direction .....	23
4.3.3	Definition of some L1 parameters .....	24
<b>5</b>	<b><i>Formatting conventions</i></b> .....	<b>46</b>
5.1	<b>Format for L1 product</b> .....	<b>46</b>
5.1.1	Megha-Tropiques Data products Distribution requirements .....	46
5.1.2	Basic Elements of HDF5 : .....	47
5.1.3	MT Level-1 file structure .....	50
5.2	<b>Data type conventions</b> .....	<b>50</b>
5.3	<b>File naming Convention</b> .....	<b>51</b>
5.4	<b>Product Identification code</b> .....	<b>54</b>
5.5	<b>data compression</b> .....	<b>54</b>
<b>6</b>	<b><i>Detailed definition of L1 products</i></b> .....	<b>55</b>
6.1	<b>Definition of L1A products</b> .....	<b>55</b>
6.1.1	MADRAS L1A products definition.....	55
6.1.2	SAPHIR L1A products definition .....	56
6.1.3	SCARAB L1A products definition.....	57
6.2	<b>General Definition of L1 A2 products</b> .....	<b>58</b>
6.2.1	Definition of MADRAS L1A2 product.....	58
6.2.2	Definition of SAPHIR L1A2 product.....	61
6.2.3	Definition of Scarab L1A2 products .....	62
6.2.4	Content of SCARAB L1A2 file.....	62
6.2.5	Definition of L1A3 PRODUCTS: based ON 89GHZ MADRAS grid.....	63
6.2.6	MADRAS L1A3 product .....	65
6.2.7	SAPHIR L1A3 product .....	65
6.2.8	SCARAB L1A3 product.....	65



C.N.E.S./ I.S.R.O.	<b>Megha-Tropiques</b>	Réf. TRO-0-ST-1610-CNES Ed: 3 Date: Jan17th 2013 Issue : 4 Page : 9
--------------------	------------------------	--

<b>6.3</b>	<b>Definition of L1B PRODUCTS: based ON GEOMETRIC SWATH GRID.....</b>	<b>66</b>
6.3.1	MADRAS content in L1B .....	67
6.3.2	SAPHIR content in L1B product.....	68
6.3.3	SCARAB content of L1B product.....	68
<b>7</b>	<b><i>Interface with mission center .....</i></b>	<b>69</b>
<b>8</b>	<b><i>LEVEL 1 archive .....</i></b>	<b>69</b>

C.N.E.S./ I.S.R.O.	<h1>Megha-Tropiques</h1>	Réf. TRO-0-ST-1610-CNES Ed: 3 Date: Jan17th 2013 Issue : 4 Page : 10
--------------------	--------------------------	---

## 1 PURPOSE

The objective of this document is to define Level 1 products to be disseminated to all science users.

Products for expertise are not mentioned in that document.

Section 3 provides a general description of MADRAS, SAPHIR and SCARAB instruments and the other sections define the L1 products.

## 2 REFERENCE AND APPLICABLE DOCUMENTS

### 2.1 APPLICABLE DOCUMENTS

Index	Title of document	Reference
<u>AD 1</u>	System document	TRO-SP-0-208-CNES
<u>AD 2</u>	Excel sheet for format details	ProductDefinition_MADRAS_L1A-1-1-2-3-B_HDFMGTStructure_13rev0.xls ProductDefinition_SAPHIR_L1A-1-2-3-B_HDFMGTStructure_13rev0.xls ProductDefinition_SCARAB_L1A-1-2-3-B_HDFMGTStructure_13rev0.xls
<u>AD 3</u>	L0 Products .definition	MT/ISAC/ICD-level 0
<u>AD4</u>	Data Products Plan for Megha Tropiques	ISRO-MT-SAC-DP 38 – 2007
<u>AD5</u>	Algorithms for generating MADRAS Level-1 Data Products	ISRO-MT-SAC-DP 39 – 2008
<u>AD6</u>	Saphir L1 processing algorithm requirements	TRO-33- ST1602- CNES
<u>AD7</u>	Scarab : L1A processing requirements	TRO-34-ST-1413- CNES
<u>AD8</u>	MADRAS L1A processing algorithm requirements	TRO-32-ST-1619-CNES
<u>AD9</u>	MADRAS level 1-A2 processing algorithm requirement	TR0- 32-ST-2567-CNES
<u>AD10</u>	SAPHIR L1A2 Processing algorithm	TRO-33-ST-2720-CNES
<u>AD11</u>	SAPHIR L1A3 Processing algorithm	TRO-33-ST-2725-CNES
<u>AD12</u>	SCARAB L1A2 Processing	TRO-34-ST-2751-CNES
<u>AD13</u>	SCARAB L1A3 Processing	TRO-34-ST- 2776-CNES

C.N.E.S./ I.S.R.O.	<h1>Megha-Tropiques</h1>	Réf. TRO-0-ST-1610-CNES Ed: 3 Date: Jan17th 2013 Issue : 4 Page : 11
--------------------	--------------------------	---

## 2.2 REFERENCE DOCUMENTS

Index	Title of document	Reference
<u>RD1</u>	Mission Rationale	TRO-MTO-SP-209-CNES
<u>RD2</u>	Megha Tropiques Ground Segment and Data Products	International Conference on Megha-Tropiques – Science & Applications, March 23-25, 2009, Bangalore
<u>RD3</u>	HDF5 User's Guide,	Release 1.8.3 May, 2009, <a href="http://www.hdfgroup.org/HDF5/doc/PSandPDF/HDF5_UG_r183.pdf">http://www.hdfgroup.org/HDF5/doc/PSandPDF/HDF5_UG_r183.pdf</a>

## 3 INSTRUMENTS GENERAL DESCRIPTION

The MEGHA-TROPIQUES satellite is dedicated to the study of the atmospheric water cycle and energy budget in the tropical atmosphere. Its orbit, slightly inclined relative to the equator (20°), will allow it to obtain measurements with an excellent revisit rate.

The satellite will carry four instruments:

- The MADRAS microwave radiometer, the mission's main instrument, designed to measure precipitation and cloud characteristics,
- The SAPHIR microwave radiometer sounder, for calculating the vertical profiles of water vapour in the atmosphere,
- The SCARAB broadband optical radiometer, for measuring radiation fluxes at the top of the atmosphere,
- The GPS radio-occultation receiver, for determining atmospheric temperature and humidity.

The present document will address only the MADRAS, SAPHIR and SCARAB L1 products definition.

### 3.1 MADRAS INSTRUMENT

The MADRAS microwave radiometer is a passive instrument based on the principle of the total power radiometer. It collects the radiation emitted by the Earth/atmosphere system in various channels (frequency bands). The selected channels, 18, 23, 36, 89 and 157 GHz, have been chosen for the study of precipitation and cloud characteristics.

The 9 channels MADRAS radiometer main characteristics are listed in the following tables:

Channels	Central nominal frequency	Polarisation	Bandwidth
M1-H	18,7 GHz	H	±100 MHz

M1-V	18,7 GHz	V	±100 MHz
M2-V	23,8 GHz	V	±200 MHz
M3-H	36,5 GHz	H	±500 MHz
M3-V	36,5 GHz	V	±500 MHz
M4-H	89 GHz	H	±1350 MHz
M4-V	89 GHz	V	±1350 MHz
M5-H	157 GHz	H	± 1350MHz
M5-V	157 GHz	V	± 1350MHz

Tableau 3.1-1: MADRAS channels

In order to cover a swath of around 1700Km with a constant incidence angle on all pixels, the radiometer’s antenna carries out a conical scan at an angle of 45° to the nadir. The following illustration shows the geometry of the image capture as well as the distribution of the pixels projected onto the ground:

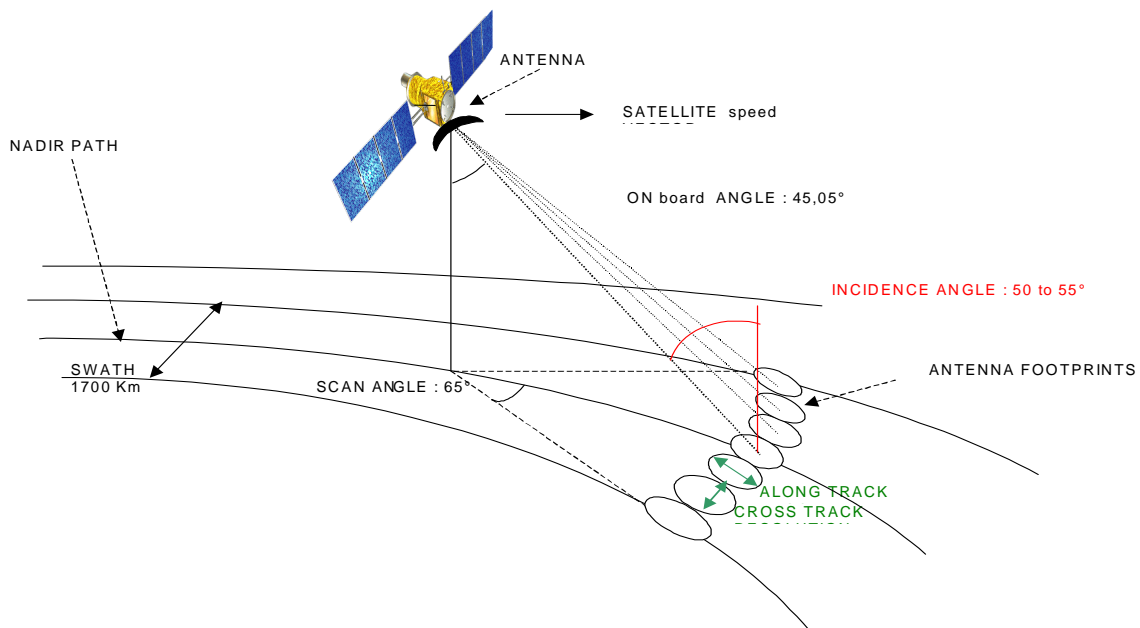

Figure 3.1-1: Imaging geometry of MADRAS

The main characteristics of the scan are the following:

Scan type	Conical at constant speed
Scan coverage	± 65°
Scan rate	24,1495rev/mn (2,4845sec)
Incidence angle	53,5°

Table 3.1-2: Typical Scanning characteristics of MADRAS

C.N.E.S./ I.S.R.O.	<b>Megha-Tropiques</b>	Réf. TRO-0-ST-1610-CNES Ed: 3 Date: Jan17th 2013 Issue : 4 Page : 13
--------------------	------------------------	---

The radiometer footprint (or IFOV) is defined as the intersection of half power beam width of the antenna main lobe and the earth surface. Due to the conical scanning of the antenna beam, the footprints are in the shape of ellipses. The cross track spatial resolution corresponds to the minor diameter of the elliptical footprint, the along track resolution corresponds to the major diameter.

The size of the footprint (cross and along track resolution) is given in the following table:

Channels	Cross track resolution	Along track resolution
M1-H, M1-V, (18,7 Ghz) M2-V (23,8 Ghz) M3-H, M3-V (36,5 GHz)	40 Km	67.25 Km
M4-H, M4-V (89Ghz)	10 Km	16.81 Km
M5- H, M5-V (157 GHz)	6 Km	10.1 Km

*Table 3.1-3: MADRAS footprint*

The dwell time is defined as the time taken by the antenna to move a distance of one footprint, the scan speed being constant, the dwell time could be calculated for each channel.

Pixels are defined as adjacent IFOV in cross track direction.

To obtain the specified pixels with the following resolution and achieve the requested radiometric sensitivity, data is oversampled on board in the cross track direction. Values of samples are encoded on 12bits, collected in the science telemetry packets and transmitted on ground. Automatic loop is onboard to control gain and offset of the MADRAS receivers.

The same number of samples is collected every scan line. In fact, for each scan, the valid data are those covering the  $\pm 65^\circ$  angles. Some extra samples beyond  $\pm 65^\circ$  are acquired on board.

No processing is performed on board.

During each scan period, calibration of the radiometer is performed on an internal hot load during some period of time and on a cold sky. In the same way, hot load and cold sky samples are acquired on board. Some extra samples are acquired on board beyond the calibration zone.

The following table provides for each channel, the dwell time, and the number of pixels per scan:

	Resolution	Dwell time	Number of pixels per scan
<u>LF channels : 18/23/36GHz</u> Channels M1 to M3	40Km	16,8 ms	54
<u>MF Channel : (89GHz)</u> Channel M4	10Km	4,2 ms	214
<u>HF channels</u> Channels M5	6Km	2,5 ms	356

*Table 3.1-4: characteristics of MADRAS channels*

The next table gives the sampling time, and number of samples given in the science telemetry and the total number for earth acquisition data and calibration data.

Details is given on number of hot and cold samples used for calibration purpose.

	Sampling time	Number of Total samples per scan in the format (cf : ISRO format)
<u>LF channels : 18/23/36GHz</u> Channels M1 to M3	2ms	480
<u>MF Channel : (89GHz)</u> Channel M4	2ms	480
<u>HF channels (157GHz)</u> Channels M5	1ms	960

Table 3.1-5: Number of samples for earth acquisition data

	Sampling time	Duration for hot Calibration	Duration for Cold calibration	Hot calibration Number of Valid samples (Total acquired samples)	Cold calibration Number of Valid samples (Total acquired samples)
<u>LF channels : 18/23/36GHz</u> Channels M1 to M3	2ms	108.39ms	43.49ms	<b>Valid = 56</b> (72)	<b>Valid = 23</b> (40)
<u>MF Channel : (89GHz)</u> Channel M4	2ms	122.06ms	43.5ms	<b>Valid=62</b> (72)	<b>Valid =23</b> (40)
<u>HF channels</u> Channels M5	1ms	142.09ms	43.49ms	<b>Valid =143</b> (144)	<b>Valid = 45</b> (80)

Table 3.1-6: : Number of samples for calibration data

The number of the first/last valid samples of the 3 zones: earth observation (if limited to +/- 65°), hot calibration, cold calibration is as follows:

	First/Last sample number for Earth zone ( $\pm 65^\circ$ )	First/Last sample number for Hot calibration zone	First/Last sample number for Cold calibration zone
<u>LF channels :</u> <u>18/23/36GHz</u> Channels M1 to M3	<b>12 / 469</b>	<b>7 / 62</b>	<b>8 / 30</b>
<u>MF Channel :</u> <u>(89GHz)</u> Channel M4	<b>16 / 466</b>	<b>5 / 66</b>	<b>8 / 30</b>
<u>HF channels</u> Channels M5	<b>31 / 930</b>	<b>0 / 142</b>	<b>16 / 60</b>

Tableau 3.1-7: Number of the valid samples

The rotation speed has been defined in order that samples/pixels corresponding to 2 consecutive scan lines are overlapped by 10% for 89GHz channels. Then, pixels of 2 consecutive scan lines at low frequency are significantly overlapped and a gap exists between two consecutive scan lines for 157 GHz pixels.

The dynamic range of MADRAS radiometer brightness temperature is 3K to 320K.

### 3.2 SAPHIR INSTRUMENT

The SAPHIR instrument is multi-channel passive microwave humidity sounder. Atmospheric humidity profiles can be obtained by measuring brightness temperatures in different channels situated close to the 183.31 GHz water vapour absorption line.

The channels characteristics are specified in the following table:

Channels	Central nominal frequencies (GHz)	Channels bandwidth
S1	$183,31 \pm 0,2$	200MHz
S2	$183,31 \pm 1,1$	350MHz
S3	$183,31 \pm 2,8$	500MHz
S4	$183,31 \pm 4,2$	700MHz
S5	$183,31 \pm 6,8$	1200MHz
S6	$183,31 \pm 11$	2000MHZ

Table 3.2-1: SAPHIR channels



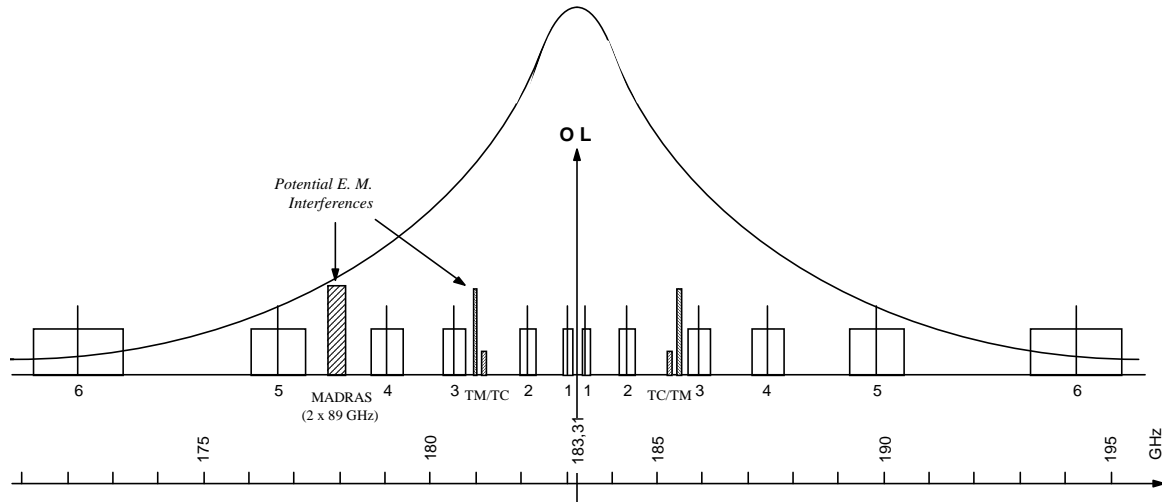

Figure 3.2-1: Repartition of water vapour channels

The dynamic range of SAPHIR radiometer brightness temperature is 4K to 313K.

To ensure large swath coverage, the narrow beam of the antenna is performing a Nadir across track scanning when the satellite is moving ahead. The following illustration shows the imaging geometry.

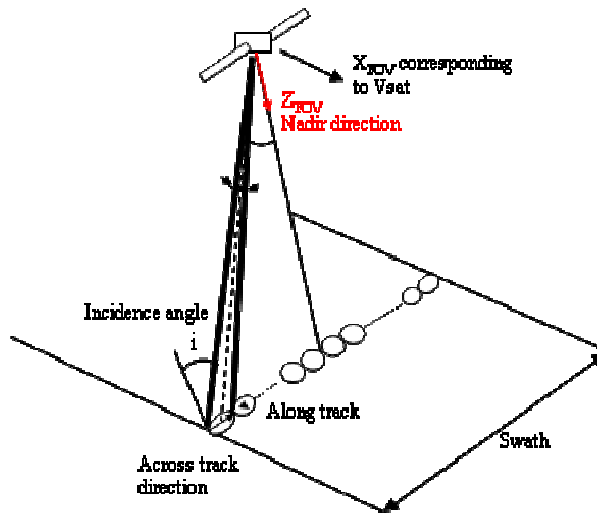

Figure 3.2-2: Imaging geometry of SAPHIR

The IFOV (footprint) is defined as the intersection of half power beam-width of the antenna main lobe and the earth surface. Due to the scanning of the antenna beam in the cross-track direction, the shape and the size of the instantaneous footprint change from a circle at Nadir to ellipses of different size over the swath. The basic resolution of 10 km is defined for the

Nadir footprint. The rotation speed has been defined to ensure that at Nadir, pixels of two consecutive scan lines are adjacent.

The main characteristics of scan parameters are:

Scan type	Cross track scanning at constant speed
Scan period	1,638 seconds (36,63 rev/min)
Incidence angle	Variable along swath
Polarisation	Variable along swath
Scan angle coverage ( $\pm 65 \theta_{3dB}$ )	$\pm 42,96^\circ$ around Nadir

*Table 3.2-2: Scanning characteristics of SAPHIR*

The number of specified pixels (non-overlapping footprint or IFOV) per scan line and per channel is 130, the dwell time is 6,406ms.

To obtain the specified pixels with the following resolution and achieve the requested radiometric sensitivity, data are oversampled on board in the cross track direction by a factor of 4. The sampling time is 4,576ms. Values of samples are encoded on 16bits, collected in the science telemetry packets and transmitted on ground.

The same number of samples is collected every scan line and for each channels. The number of samples collected over the earth/atmosphere corresponds to 182 samples per scan line.

Samples are to be interpolated to generate the specified pixels.

No processing is performed on board.

In each scan, the receivers are calibrated using an internal hot load, and using the same antenna for sky-looking.

The number of valid hot calibration samples per scan line and per channel is 7.

The number of valid cold calibration samples per scan line and per channel is 7.

### 3.3 SCARAB INSTRUMENT

SCARAB is an optical scanning radiometer devoted to the measurements of radiative fluxes at the top of the atmosphere. The optical radiometer is composed of 4 parallel and independent telescopes focusing the reflected solar and emitted thermal radiation of the earth atmosphere on 4 detection channels. Channel 2 and channel 3 are considered as the main channels, channel 2 providing directly the solar energy reflected by the earth- atmosphere, channel 3 measuring the total energy (solar and thermal). Channel 1 and channel 4 are narrow band channels used for scene identification in the visible (channel 1) and in the Infrared (channel 4) domains.

The main channels characteristics are listed in the table hereafter:

Channel	Wavelength
SC1 - Visible	0,5 to 0,7 $\mu\text{m}$
SC2 - Solar	0,2 to 4 $\mu\text{m}$
SC3 - Total	0,2 to 50 $\mu\text{m}$
SC4 - IR Window	10,5 to 12,5 $\mu\text{m}$

Table 3.3-1: SCARAB channels

To ensure a swath of about 2200km, a cross track scanning of the instrument is performed. The cross track scanning is obtained by the rotation of the telescopes and associated detectors in the Nadir plane, which is perpendicular to the satellite speed vector.

The footprint size of a radiometer sample is defined by detector channel characteristics and is varying from 40km at Nadir to 200Km on the edge.

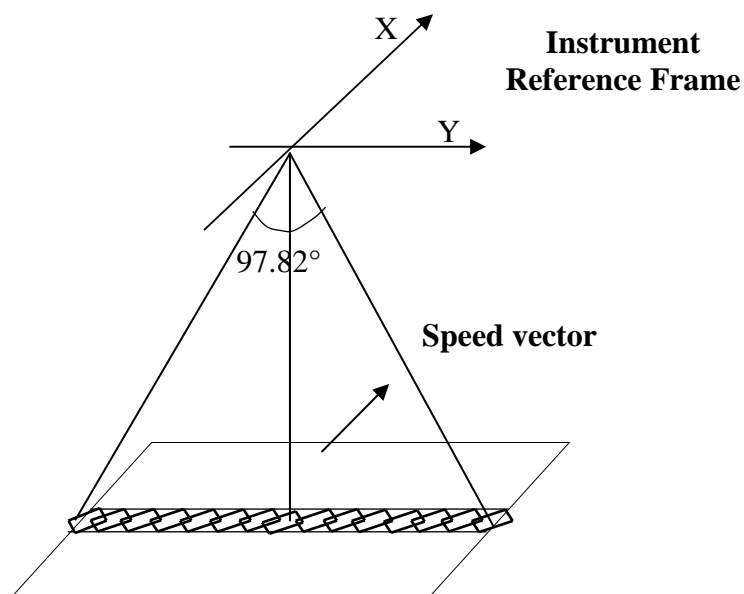

Figure 3.3-1: ScaRaB imaging geometry.

51 measurements per scan line and per channel are collected when the radiometer is scanning the earth surface over  $\pm 48.91^\circ$ .

These measurements correspond to overlapped pixels on ground by definition.

The raw science data acquired on board corresponds to overlapped pixels as defined by the science community.

The characteristics of the scan are the following:

Scan type	Cross track scanning at constant speed over the earth/atmosphere observation
Scan period	6 seconds
Acquisition angle	$\pm 48,91^\circ$ around Nadir
Angular sampling	34,15mrad corresponding to 62,5ms

*Table 3.3-2: scan characteristics of SCARAB*

The sample size is varying along the swath with the following characteristics:

	At Nadir	Pixel 0 and N°50
Sample size diagonal across track	58,72 Km	192,04 Km
Sample size diagonal along track	58,72 Km	99, 27Km

*Table 3.3-3: Samples size of SCARAB*

Every scan period, a space view measurement is performed for calibration, three samples are measured per channel per scan.

C.N.E.S./ I.S.R.O.	<h1>Megha-Tropiques</h1>	Réf. TRO-0-ST-1610-CNES Ed: 3 Date: Jan17th 2013 Issue : 4 Page : 21
--------------------	--------------------------	---

## 4 DEFINITION OF L1 DATA PRODUCT

4 types of L1 products will be disseminated to science users: L1A, L1A2, L1A3, and L1B. The products are defined in the following sections.

In the frame of the MEGHA-TROPIQUES, some L1 products have to be disseminated in Near Real Time. They will be mentioned as NRT products and the other products as standard products.

All products L1A, L1A2, L1A3 and L1B will be available as standard and NRT products

### 4.1 STANDARD PRODUCT

- ⇒ Standard products are defined orbit wise
- ⇒ Data latency of standard products is six hours (TBC) from data acquisition in nominal situation at ISSDC.

### 4.2 NRT PRODUCTS

- ⇒ NRT products are dumping wise products. The amount of data of one NRT file will depend on the quantity of data transmitted to the ground station over one pass. Generally, the size of a NRT product will on average be equal to one orbit's data.
- ⇒ Data latency of the NRT products is expected to be less than 3 hours from sensing to users.

### 4.3 GENERAL CHARACTERISTICS OF PARAMTERS

#### 4.3.1 Satellite modes

##### Satellite flip and orbit manoeuvres:

Satellite is required to flip around yaw axis by 180° in order to avoid sun entry in some platform equipment. Typically a few times per year.

Duration of a manoeuvre is approximately 20 minutes.

##### Satellite modes conventions:

The following satellite modes defined by ISRO are identified, the related code information is provided:

Satellite Mode	Flag convention			Explanations	L1 data valid or Invalid
	MSB		LSB		
1	0	0	0	No Flip condition equivalent forward configuration	Valid
2	0	0	1	Flip Transition	Invalid L1 data in products
3	0	1	0	Flipped condition equivalent to backward configuration	Valid
4	0	1	1	Attitude manoeuvres for orbit maintenance	Invalid L1 data in products
5	1	0	0	Attitude manoeuvres for payload calibration purpose	For Calibration purpose L1 product not disseminated (expertise product only )
6	1	0	1	Attitude bias for payload operation	For Calibration purpose L1 product not disseminated (expertise product only )
7	1	1	0	Gyro calibration	Invalid L1 data in products
8	1	1	1	MADRAS in fixed Mode	For Calibration purpose L1 product not disseminated (expertise product only )

Table 4.3-1: Satellite mode conventions

### 4.3.2 Scanning Direction

The MADRAS instrument scanning direction is anti-clockwise around yaw direction as observed from “-Yaw “

SAPHIR and SCARAB instruments scanning from “+Pitch” to “+Yaw” as observed from “+Roll”.

The sequence in which samples will be acquired depends on flip status and scan direction.

The imaging geometry is termed as forward or backward as explained in Fig 1 for MADRAS payload and in Fig 2 for SCARAB & SAPHIR payloads.

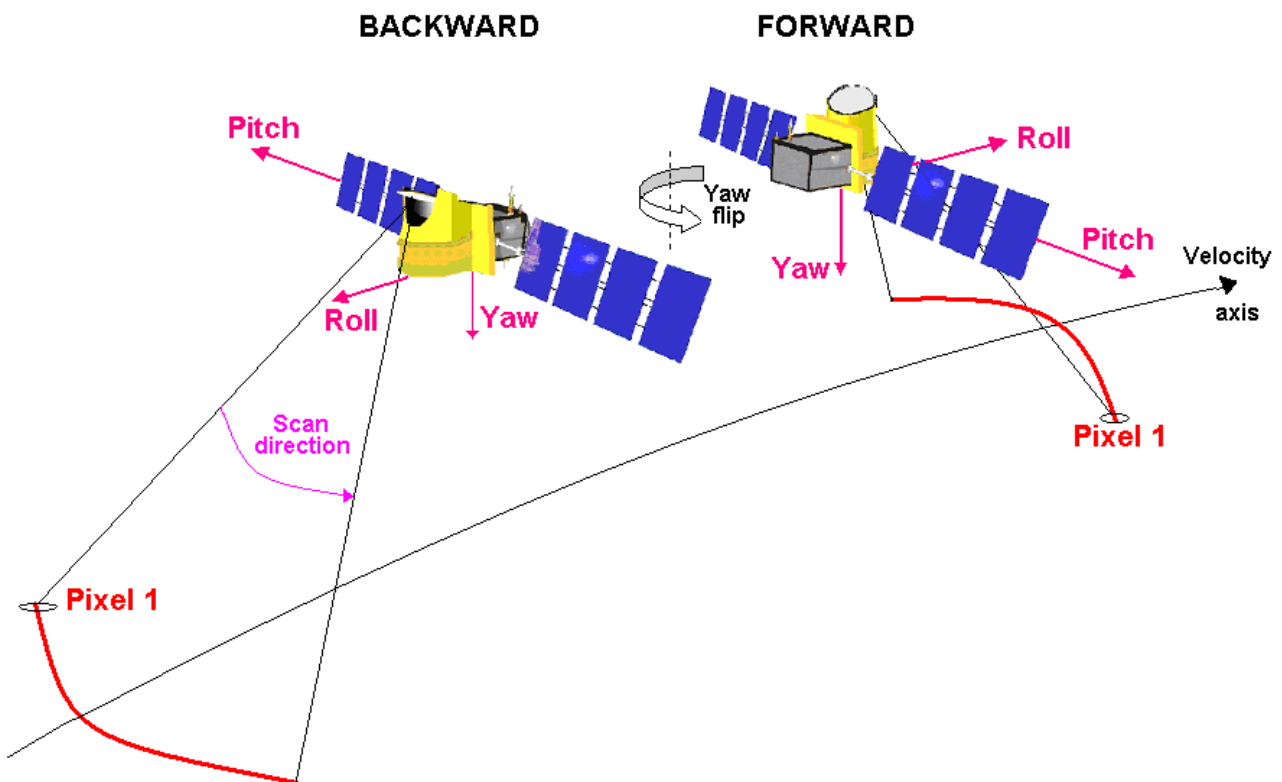

Figure 4.3-1: MADRAS scans line geometry: forward and backward definition

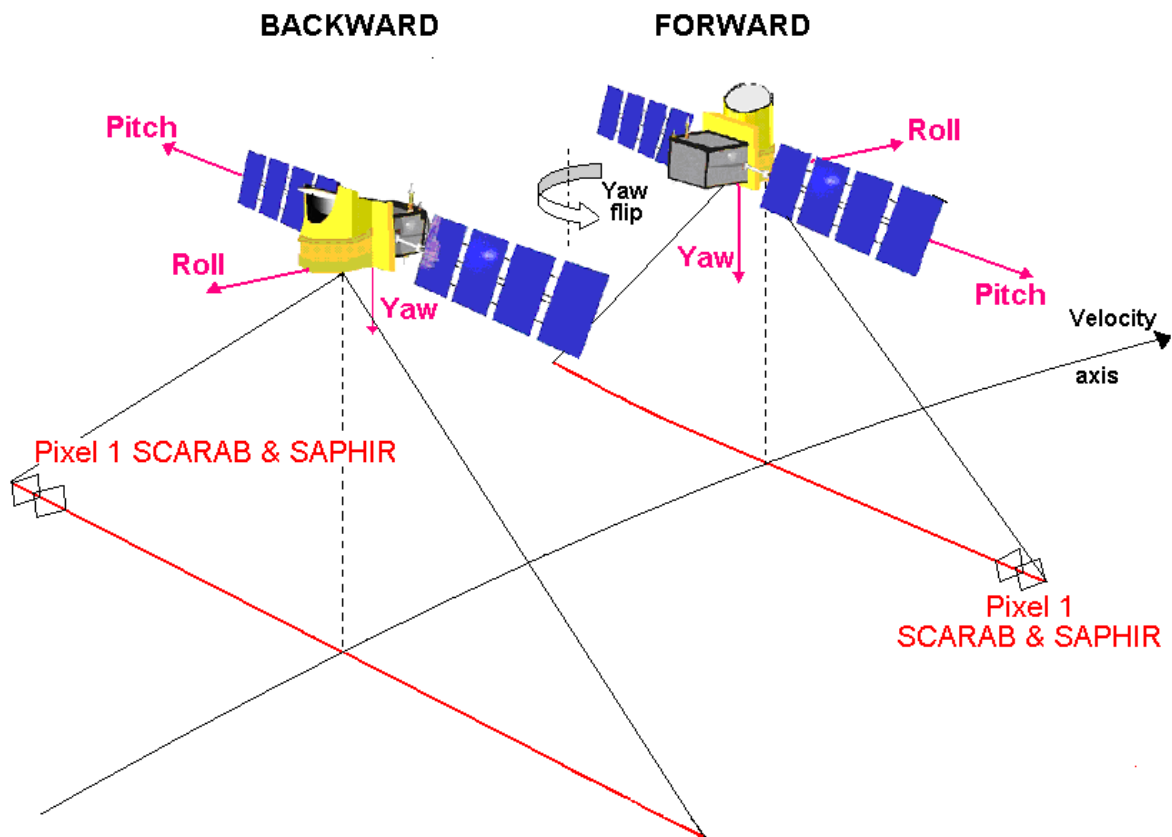

Figure 4.3-2: SAPHIR and SCARAB scan line geometry: forward and backward definition

### 4.3.3 Definition of some L1 parameters

The following definition will be taken into account in the L1 product parameters definition.

#### 4.3.3.1 Orbit

- The orbit altitude is about 865,5 km and inclination 20°.
- Orbit is 7 days phased orbit, the ground track repeats itself after 97 revolutions. The longitude separation between successive orbits is about 25, 98°. The ground track will be maintained within 10km limits.
- Orbit number is increased by one at every ascending cross over.

#### 4.3.3.2 Geodetic Latitude

- The geodetic Latitude (angular distance between Zenith of each place and equator) will be provided for SAPHIR and MADRAS, and also for the products L1A3 et L1B of SCARAB (combined products).



C.N.E.S./ I.S.R.O.	<h1>Megha-Tropiques</h1>	Réf. TRO-0-ST-1610-CNES Ed: 3 Date: Jan17th 2013 Issue : 4 Page : 25
--------------------	--------------------------	---

- Convention : -90/ +90° ( 0° corresponds to equator, +90° is north and -90° is south).

#### 4.3.3.3 Geodetic Co-Latitude

- Geodetic Co-latitude (angular distance between the north pole and the zenith of each place) will be provided for the products L1A and L1A2 of SCARAB.
- Convention : 0/180° ( 0° corresponds to north, 90° is equator and 180° is south).

#### 4.3.3.4 Longitude

- Convention : 0 to 360°, starting from Greenwich (0) and rotating towards the East.

#### 4.3.3.5 Longitude and latitude at Nadir

- Longitude and latitude at Nadir is computed at the time of the first pixel /sample for L1A and L1A2 products .

#### 4.3.3.6 Time unit

- UTC time : it is a time standard based on International Atomic Time (TAI) with leap seconds added at irregular intervals to compensate for the Earth's slowing rotation. Leap seconds are used to allow UTC to closely track UT1, which is mean solar time at the Royal Observatory, Greenwich. The difference between UTC and UT1 is not allowed to exceed 0.9 seconds. The leap second will be handled at level 0 processing .

#### 4.3.3.7 Viewing zenith angle (SCARAB) or incidence angle (MADRAS, SAPHIR)

The satellite viewing zenith angle at pixel centre ( $\theta_v$ ) is the angle in degrees between  $\vec{Z}_e$  (zenith) and  $\vec{VD}$  (viewing direction). Assuming that (N, W, Ze) is the local referential, earth tangent in P. P is the pixel centre on earth surface.

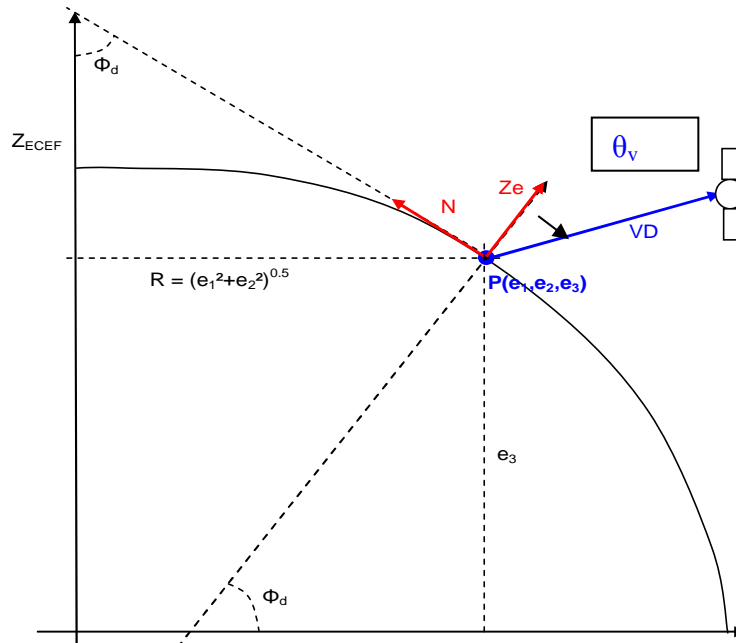

Figure 4.3-3: Viewing zenith angle or incidence angle

$(\Phi_d)$  is the geodetic latitude.

The viewing zenith angle ( $\theta_v$ ) is the angle in degrees between  $\vec{Z}_e$  and  $\vec{VD}$ .

Definition of satellite azimuth viewing angle at pixel centre

Let  $\vec{VD}_t$  be the projection of  $\vec{VD}$  in the plane  $(\vec{N}, \vec{W})$ .

The satellite azimuth viewing angle ( $\varphi_v$ ) is the angle in degrees between the local North  $\vec{N}$  and  $\vec{VD}_t$ .  $\varphi_v$  is computed from North and is positive (between 0 to 180°) if  $VD_t$  is located on the East side of the reference frame and negative (between 0 and -180°) if  $VD_t$  is located on west side

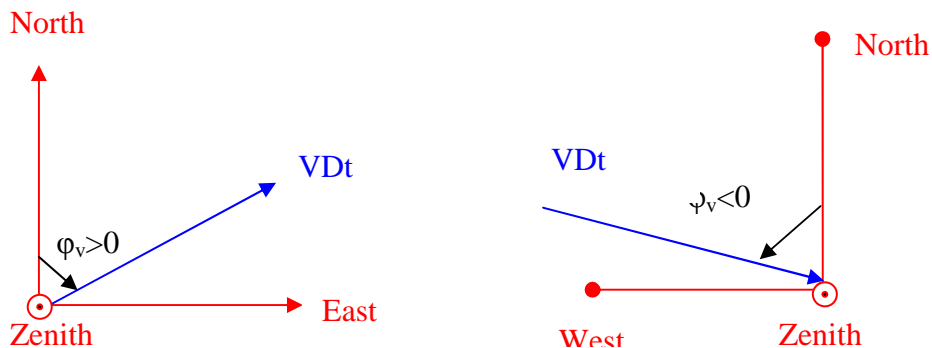

Figure 4.3-4: Viewing azimuth angle at pixel center

Finally, 0° corresponds to North, +180 and -180° azimuth correspond to south, +90° azimuth correspond to East and -90° to West

### 4.3.3.8 Solar Zenith angle

The same conventions are used to define the solar zenith and azimuth angles at pixel centre, replacing the viewing direction by the sun direction  $\vec{SD}$  (vector from P to the sun):

The solar zenith angle ( $\theta_s$ ) is the angle in degrees between  $\vec{Z}_e$  and  $\vec{SD}$ .

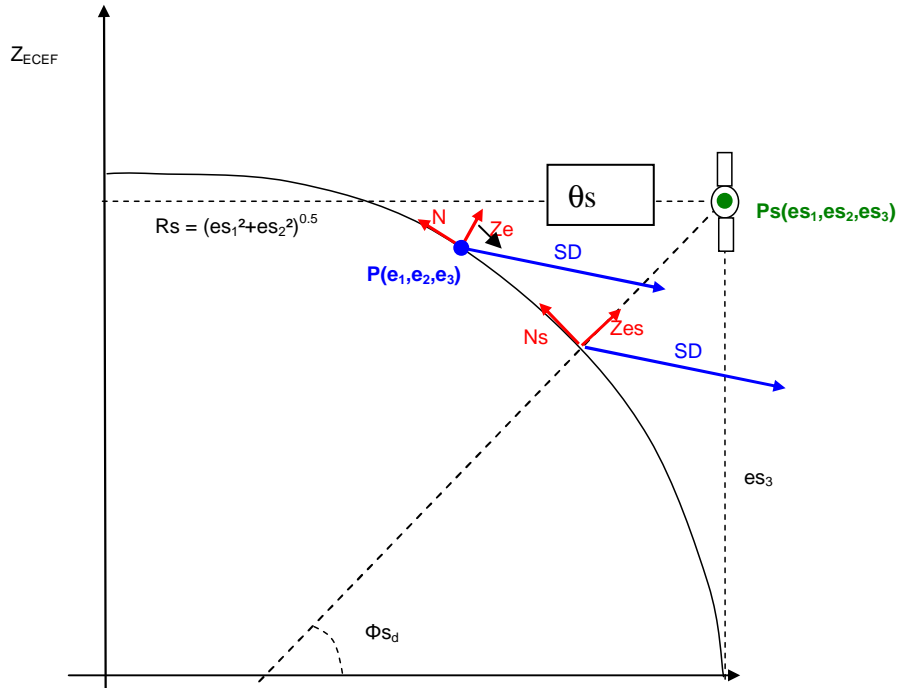
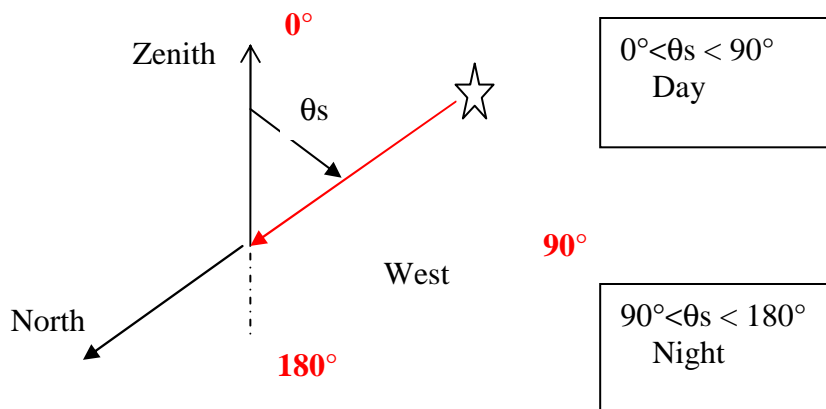

Figure 4.3-5: Solar viewing angle



The solar zenith angle is varying from 0 to 180°, if the angle is between 0 and 90°, it corresponds to day time and if the angle is varying from 90 to 180°, it corresponds to night

Let  $\vec{SD}_t$  be the projection of  $\vec{SD}$  in the plane  $(\vec{N}, \vec{W})$ .

The solar azimuth angle ( $\phi_s$ ) is the angle in degrees between  $\vec{N}$  and  $\vec{SD}_t$ .  $\phi_s$  is from the North axis .

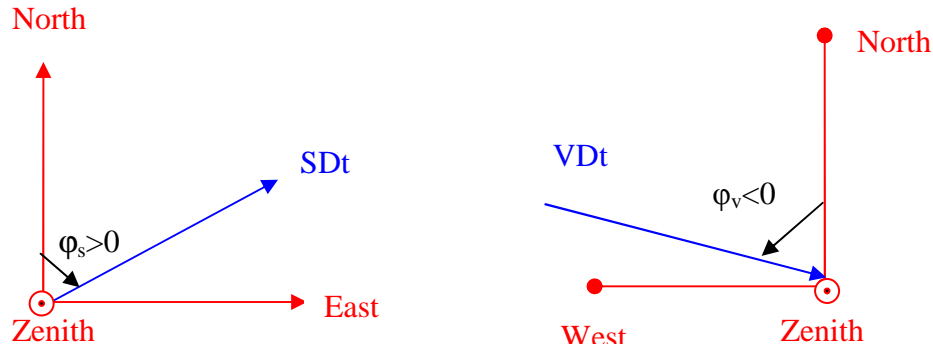

Figure 4.3-6: Solar azimuth angle at pixel center

Finally,  $0^\circ$  azimuth corresponds to North ,  $+180$  and  $-180^\circ$  azimuth correspond to south,  $+90^\circ$  azimuth correspond to East and  $-90^\circ$  to West

#### 4.3.3.9 Relative azimuth angle

Relative azimuth angle = Solar azimuth angle – Viewing azimuth angle .

The relative azimuth angle can vary between 0 and  $360^\circ$

#### 4.3.3.10 Sun glint detection

**Sunglint** is a phenomena that occurs when the sun reflects off the surface of the ocean at the same angle that the satellite sensor is viewing the surface. To detect this phenomena , a flag will be raised when pixels/samples are likely affected by Sun glint (specular reflectance of Sun light over the observed surface).

For a perfectly flat surface and a given viewing geometry, the geometry is described in the 2 figures below :

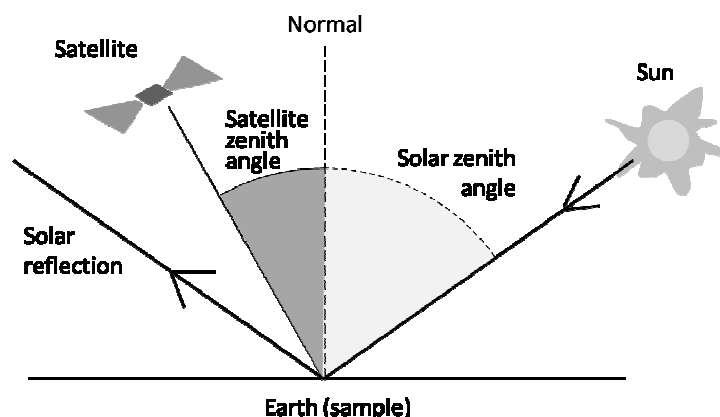

Figure 4.4.3.9-1 : Sun glint geometry : illustration of solar reflection vector

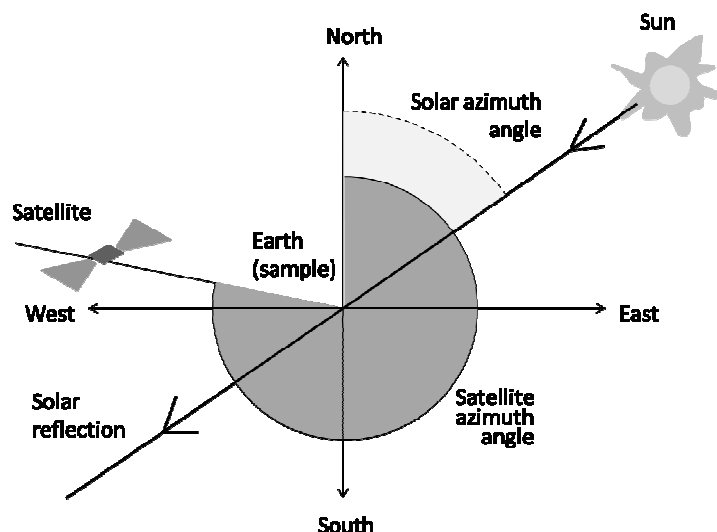

Figure 4.4.3.9-2 : Sun glint geometry in azimuth plane where sun and satellite angles vectors projected on the plane tangent to the Earth's surface.

Then, for a flat surface, and sun and instrument being considered as points, a sun glint event happens when the following solar and viewing angles are fulfilling the formula below :

$$\text{Solar\_Angle\_zenith} = \text{Viewing\_Angle\_zenith}$$

$$\text{Solar\_Angle\_azimuth} = \text{Viewing\_Angle\_azimuth} - 180^\circ$$

In fact, as the sun has an angular diameter of  $0.53^\circ$ , there will be a range of specular reflection angle that can reflect light from some part of the sun disc's into the radiometer. In addition, surfaces observed by the instrument are not perfectly flat; they exhibit roughness at very different scales. These many tiny facets of varying slope and orientation will reflect incident sun light in a wide-ranging direction.

Then, to take into account these items, a flag will be raised when computed solar angles are within a cone angle closed to the value of the above formula. The limits will be identified as parameters and could be modified if required after launch.

C.N.E.S./ I.S.R.O.	<b>Megha-Tropiques</b>	Réf. TRO-0-ST-1610-CNES Ed: 3 Date: Jan17th 2013 Issue : 4 Page : 30
--------------------	------------------------	---

#### 4.3.3.11 Datation of samples and pixels

##### Datation of MADRAS L1A samples

As samples are acquired at regular period within a scan line, for each sample, the date is obtained by the date of the first sample given in the header plus the number of instrument sample acquisition period depending on sample position.

For each scan,

Date of MF Sample (n) = Scan\_FirstSampleAcqTime + n \* (LF\_Sample\_AcquisitionPeriod))

Date of LF Sample (n) = Scan\_FirstSampleAcqTime + n \* (MF\_Sample\_AcquisitionPeriod)

Date of HF Sample (n) = Scan\_FirstSampleAcqTime + n \* (HF\_Sample\_AcquisitionPeriod)

##### Datation and L1A3/L1A2 MADRAS pixels

For the same reasons as above, date of pixels in the scan is as follows

For each scan,

Date of MF pixels (n) = MF\_Scan\_FirstPixelAcqTime + n \* (Pixel\_AcquisitionPeriod))

Date of LF pixels (n) = LF\_Scan\_FirstPixelAcqTime + n \* (Pixel\_AcquisitionPeriod)

Date of HF pixels (n) = HF\_Scan\_FirstPixel AcqTime + n \* (Pixel \_ AcquisitionPeriod)

The pixel acquisition period corresponds to the time interval between 2 consecutive 10km 89GHz pixels

##### Datation of SAPHIR L1A Samples

As samples are acquired at regular period, for each sample the date is derived for the date of the first sample given in the header plus the number of instrument sample acquisition period from first sample to the current sample

Date of SAPHIR sample (n) = Scan\_FirstSampleAcqTime + n \* (Sample Acquisition Period)

##### Datation of SAPHIR L1A2 pixels

For the same reasons as above, date of pixels in the scan is as follows

For each scan,

Date of SAPHIR pixel (n) = Scan\_FirstPixelAcqTime+ n \* (Pixel Acquisition Period)

##### Datation of Scarab L1A/L1A2 samples

As samples are acquired at regular period, for each sample the date is derived for the date of the first sample given in the header plus the number of instrument sample acquisition period from first sample to the current sample

Date of SCARAB sample (n) = Scan\_FirstSampleAcqTime + n \* (Sample Acquisition Period)

##### Datation of SAPHIR/SCARAB L1A3

Date of SCARAB (SAPHIR ) (n) = Scan\_FirstpixelAcqTime + Pixel Acquisition time(n)

The “pixel acquisition time” corresponds to time interval elapsed from “Scan first pixel Acquisition time”

C.N.E.S./ I.S.R.O.	<b>Megha-Tropiques</b>	Réf. TRO-0-ST-1610-CNES Ed: 3 Date: Jan17th 2013 Issue : 4 Page : 31
--------------------	------------------------	---

### **Datation of MADRAS/SAPHIR /SCARAB L1B cells**

Date of MADRAS or SCARAB or SAPHIR cell (n) , only time of the row will be provided (Row \_First cell AcqTime )

#### **4.3.3.12 Definition of Level-1 Product Quality flags**

The MT-products are archived with three levels of Quality flag. These are as follows

- Product level Quality flag
- Scan level or row level Quality flag
- Sample/Pixel /cell level Quality flag
- 

##### **4.3.3.12.1 Definition of Product level Quality flag**

The product level Quality flag is defined to indicate the percentage of valid scans in the product. The invalid scans are due to number of skips existing in data stream with reference to flip transition period, attitude manoeuvres for orbit maintenance, attitude manoeuvres for payload calibration purpose, attitude bias for payload operation, Gyro calibration.

During Flip , L1data product will not be generated or scans will be declared “invalid”

During calibration modes such as MADRAS fixed mode, SAPHIR and SCARAB calibrations modes, the L1 data product will not be generated .

##### **4.3.3.12.2 Definition of Scan/row level Quality flag**

The scan/row level quality flag is defined to indicate few attributes about the particular scan/row along with the payload operation modes and satellite operation modes. Scan/row level Quality flag will be provided in short integer (16 bit) data type. The bitwise component definitions are provided in sub sections 4.4.3.12.2.1, 4.4.3.12.2.2 and 4.4.3.12.2.3 for MADRAS SAPHIR and SCARAB payloads respectively.

The definition of few scan level quality flags component is as follow :

Scan Validity / Flag:

C.N.E.S./ I.S.R.O.	<h1>Megha-Tropiques</h1>	Réf. TRO-0-ST-1610-CNES Ed: 3 Date: Jan17th 2013 Issue : 4 Page : 32
--------------------	--------------------------	---

This flag is set to value “1” to indicate users to skip these records. The flag is set to 1 in case of missing MADRAS, (SAPHIR or SCARAB) data records ,or in case of maneuvers or flip

Pass Type:

This flag is set to value “1” if pass for the current scan is Descending.

Scanning type:

This flag is set to “1” if scanning is carried out through backward scanning mode

**Remark :**

SAPHIR and SCARAB are switched to waiting mode during flip, then no data are downloaded for both instruments .

During Flip , MADRAS is maintained in nominal mode, then flip can be observed in the data flow , but satellite mode flag should be indicating “Flip transition”

Scan Error :

It is set to value “1” during satellite mode change operation or payload mode change of operation and also in fixed mode

Row error :

Same as scan error

Datation error :

It is set to value “1” if time stamping for the record in Level-0 Sensor file is not identified correctly or consistent with date of previous scans

PRT error:

It is set to value “1” if at minimum one of the Platinum Resistance Thermometer (PRT) is invalid or if dispersion on the data is not as expected

Encoder error

It is set to value “1” if Encoder error is found ; It is applicable to MADRAS

Level 0 CRC status

It is applicable to SAPHIR and SCARAB L1A, L1A2 products and will identify bit error in the L0 input data flow.

Madras correction flag :

Due to a suspected electrical interference, the MADRAS instrument , two type of observations were made :  
 - data are affected by random channel mixing. It is found that intrinsic data of the 9 channels are generally not affected but located at different positions in the transmitted data stream. A methodology has been worked out by the CNES and ISRO Project teams for realignment of the



C.N.E.S./ I.S.R.O.	<h1>Megha-Tropiques</h1>	Réf. TRO-0-ST-1610-CNES Ed: 3 Date: Jan17th 2013 Issue : 4 Page : 33
--------------------	--------------------------	---

data. With this additional processing, a significant amount of data is recoverable. All scans affected and processed for corrections are tagged (refer to bit 8 “Madras correction flag”)

This flag is set to value “1” if the data (initial L0 count value) of the scan line have been corrected. This is applicable to MADRAS L1A and L1A2, L1A3

- Another observation leads to invalid data in all the scans , these scans are not corrected but flagged invalid
- Each scan is processed independantly to avoid any error propogation

### Global consistency of corrections flag (refer to bit 7 )

Some final checks are performed on L0 data after final realignment , on each processed scan, to identify some possibly bad corrected scans. This flag is just a warning raised for users.

#### 4.3.3.12.2.1 Scan /row quality Flag for MADRAS L1A to L1B

The Scan/row quality flag is 16 bit unsigned integer parameter. Each bit of this parameter is assigned to different Quality flags which are listed in following table:

Bit no.	Quality Flag Name	Definition of bit values			
		Bit Value			Definition
15 MSB)	Scan/row validity flag	Bit = 0			Scan/row is valid
		Bit = 1			Scan/row is invalid
14	Pass Type	Bit = 0			Ascending Pass
		Bit = 1			Descending Pass
13	Scanning type	Bit = 0			Forward scanning
		Bit = 1			Backward scanning
12	Scan/row error	Bit = 0			OK
		Bit = 1			Error
11	Datation error	Bit = 0			OK
		Bit = 1			Error
10	PRT error	Bit = 0			OK
		Bit = 1			Error
9	Encoder error	Bit = 0			OK
		Bit = 1			Error
8	Madras correction flag	Bit = 0			No correction in the scan
		Bit = 1			Correction applied in the scan
7	Global consistency of corrections	Bit = 0			OK
		Bit = 1			Error
6	Blank	Bit = 0			
5-3	Payload mode	Bit 5	Bit 4	Bit 3	
		0	0	0	Nominal
		0	0	1	Calibration
		0	1	0	Fixed
		0	1	1	Invalid
2-0 (LSB)	Satellite mode	Bit 2	Bit 1	Bit 0	
		0	0	0	Valid data : No Flip condition equivalent forward configuration
		0	0	1	Invalid data: Flip Transition

		0	1	0	Valid data : Flipped condition equivalent to backward configuration
		0	1	1	Invalid data: Attitude manoeuvres for orbit maintenance
		1	0	0	Invalid data: Attitude manoeuvres for payload calibration purpose
		1	0	1	Invalid data: Attitude bias for payload operation
		1	1	0	Invalid data: Gyro calibration
		1	1	1	Valid data : MADRAS in fixed Mode (ground investigation only)

*Table 4.3-2.11.2.1: Scan quality flag for MADRAS*

#### 4.3.3.12.2.2 Scan/row Quality Flag for SAPHIR in levels L1A to L1B

The Scan quality flag is 16 bit unsigned integer parameter. Each bit of this parameter is assigned to different Quality flags which are listed in following table:

Bit no.	Quality Flag Name	Definition of bit values			
		Bit Value	Definition		
15 (MSB)	Scan/row validity Flag	Bit = 0	Scan/row is valid		
		Bit = 1	Scan/row is invalid		
14	Pass Type	Bit = 0	Ascending Pass		
		Bit = 1	Descending Pass		
13	Scanning type	Bit = 0	Forward scanning		
		Bit = 1	Backward scanning		
12	Scan/row error	Bit = 0	OK (Not applicable to L1A3)		
		Bit = 1	Error (Not applicable to L1A3)		
11	Datation error	Bit = 0	OK		
		Bit = 1	Error		
10	PRT error	Bit = 0	OK (Not applicable to L1A3)		
		Bit = 1	Error (Not applicable to L1A3)		
9- 8	blank	Bit=0			
7	CRC Status	Bit = 0	OK		
		Bit = 1	Error		
6	blank	Bit=0			
5-3	Payload mode	Bit 5	Bit 4	Bit 3	
		0	0	0	Nominal mode
		0	0	1	Fixed mode (investigation only)
		0	1	0	Hot calibration (investigation only)
		0	1	1	Cold calibration (investigation only)

2-0 (LSB)	Satellite mode	1	0	0	Nadir looking (investigation only)
		Bit 2	Bit1	Bit 0	
		0	0	0	Valid data : No Flip condition equivalent forward configuration
		0	0	1	Invalid data: Flip Transition
		0	1	0	Valid data : Flipped condition equivalent to backward configuration
		0	1	1	Invalid data: Attitude manoeuvres for orbit maintenance
		1	0	0	Invalid data: Attitude manoeuvres for payload calibration purpose
		1	0	1	Invalid data: Attitude bias for payload operation
		1	1	0	Invalid data: Gyro calibration
		1	1	1	Valid data : MADRAS in fixed Mode (ground investigation only)

*Table 4.3-3.11.2.2: Scan quality flag for SAPHIR L1A to L1B*

#### **4.3.3.12.2.3 Scan/row Quality Flag for SCARAB in levels L1A, L1A2 to L1B**

The Scan quality flag is 16 bit unsigned integer parameter. Each bit of this parameter is assigned to different Quality flags which are listed in following table:

Bit no.	Quality Flag Name	Definition of bit values		
		Bit Value	Definition	
15 (MSB)	Scan/row validity Flag	Bit = 0	Scan/row is nvalid	
		Bit = 1	Scan/row is invalid	
14	Pass Type	Bit = 0	Ascending Pass	
		Bit = 1	Descending Pass	
13	Scanning type	Bit = 0	Forward scanning	
		Bit = 1	Backward scanning	
12	Scan error	Bit = 0	OK (Not applicable to L1A3)	
		Bit = 1	Error (Not applicable to L1A3)	
11	Datation error	Bit = 0	OK	
		Bit = 1	Error	
10-8	Blank	Bit = 0		
7	Level-0 CRC Status	Bit = 0	OK	
		Bit = 1	Error	
6	Blank	Bit = 0		
5-3	Payload mode	Bit 5	Bit 4	Bit 3

Not valid for Level-1A3 & L1B

		0	0	0	Nominal mode
		0	0	1	Fixed mode (investigation only)
		0	1	0	MS calibration (investigation only)
		0	1	1	MT calibration (investigation only)
		1	0	0	C calibration (investigation only)
		1	0	1	Nadir looking (investigation only)
2-0 (LSB)	Satellite mode	Bit2	Bit1	Bit0	
		0	0	0	Valid data : No Flip condition equivalent forward configuration
		0	0	1	Invalid data: Flip Transition
		0	1	0	Valid data : Flipped condition equivalent to backward configuration
		0	1	1	Invalid data: Attitude manoeuvres for orbit maintenance
		1	0	0	Invalid data: Attitude manoeuvres for payload calibration purpose
		1	0	1	Invalid data: Attitude bias for payload operation
		1	1	0	Invalid data: Gyro calibration
		1	1	1	Valid data : MADRAS in fixed Mode (ground investigation only)

*Table 4.3-3.11.2.3: Scan quality flag for SCARAB L1A and L1A2*

#### 4.3.3.12.3 Definition of Sample/Pixel/cell level Quality flag

The sample level quality flag is defined for level-1A, pixel level quality flag for Level-1A2 products, level-1A3 product, and cell level quality flag for level-1B product. These 16bit (short integer datatype) flags are implemented to indicate information about the particular sample/pixel/cell. The bit-wise definition is presented in sub sections: 4.4.3.12.3.1 and 4.4.3.12.3.2 for MADRAS/SAPHIR and SCARAB respectively.

ON/OFF Flag:

C.N.E.S./ I.S.R.O.	<h1>Megha-Tropiques</h1>	Réf. TRO-0-ST-1610-CNES Ed: 3 Date: Jan17th 2013 Issue : 4 Page : 38
--------------------	--------------------------	---

This flag is set to bit value “1” when particular channel is “ON ” and working nominally . The parametric value of TB/Radiance value will also be assigned to a fill value if channel is OFF or declared unable for nominal use. This is fully applicable to MADRAS. In SAPHIR/SCARAB , channels can’t be switched ON/OFF separately but this could be used for invalid data in case on channel is not working properly

Sun Glint:

This flag is set to value “1” if and only if sun glint is present. The flag is not applicable to Scarab.

Surface type

With reference to a map , the flag identifies if the centre of the sample or pixel is located over Land or over the sea .

Land/sea contamination

With reference to a map , only if the pixel/sample centre is located over sea (refer to surface type flag) the flag identifies possible land contamination in an area surrounding the pixel centre and having dimensions close to pixels/sample surface.

In case the surface type flag is indicating land, the flag land/sea contamination has no significance

TB/Radiance Validity:

This flag is the representative of TB/Radiance dynamic range specification; it is set to value “1” if corresponding sample TB/Radiance value is out of dynamic range as per specification or in case of any error that might affect the proper use of data (geolocation error, scan invalid, channel OFF, calibration failure ...)

Level-0 Count error

This flag is set to value “1” if the sensor count overpass a threshold (L0 count is saturated) or if sensor count is less than a threshold (L0 count has a poor value)

TB correction flag :

This is applicable to MADRAS only .  
 Due to a suspected electrical interference, the MADRAS instrument data are affected by random channel mixing. It is found that intrinsic data of the 9 channels are generally not affected but located at different positions in the transmitted data stream.  
 A methodology has been worked out by the CNES and ISRO Project teams for realignment of the data. With this additional processing, a significant amount of data is recoverable. Not recoverable data will be tagged as filled values.

This flag is set to value “00” if no correction is applied to samples,

And 11 or 01 or 10 information is given on “complexity of corrections” . IF complexity is higher , probability to have incorrect data is getting higher . This flag is a warning to user.

Geolocation poor estimation

The flag is set to value “1” in case there is some errors in geolocation computations due to lack of OAT for example or during manoeuvres etc..

Calibration flag

The flag may corresponds to various situation

C.N.E.S./ I.S.R.O.	<h1>Megha-Tropiques</h1>	Réf. TRO-0-ST-1610-CNES Ed: 3 Date: Jan17th 2013 Issue : 4 Page : 39
--------------------	--------------------------	---

Calibration Failure:

This flag is set to value “11” if calibration process is failed for a scan due to unavailability of valid Hot count data/cold count/PRT counts data.

For MADRAS, this may indicate that the channel is saturated and data are not valid

Partial calibration:

This flag is set to value “10” if some PRT or earth count or cold count error has been encountered

In Madras the flag could be set to partial calibration if the calibration data gain, offset have been derived from previous valid calibration data

Degraded gain averaging

The flag is set to “01”, if calibration data can’t be computed averaging over a nominal number of scans

Nominal Calibration

The flag is set to “00”

Hot count error:

This flag is set to value “1” if valid hot count data is not available or erroneous. It is valid in case of MADRAS & SAPHIR sensors.

Cold Sky count error:

This flag is set to value “1” if valid Cold Sky count data is not available or erroneous.

AGC/AOC loop

The flag indicates if the loop is active or inactive . It is applicable to MADRAS only.

Spacecount error : the flag is set to “1” if the computation of space pixels mean is not erroneous

Ice flag

With reference to a map , the flag identifies if ice or no ice is possible and when map information is not available

### 4.3.3.12.3.1 Sample/pixel /cell Quality Flag for MADRAS for levels L1A, L1A2, L1A3 & L1B product

The Sample/pixel quality flag is 16 bit unsigned integer parameter. Each bit of this parameter is assigned to different Quality flags which are listed in following table:

Bit no.	Quality Flag Name	Definition of bit values		
		Value	Bit definition	
15 (MSB)	TB validity	0	Valid	
		1	Invalid	
14	Sun Glint	0	Sun Glint not present	
		1	Sun Glint present	
13	Land/Sea contamination	0	Land/Sea contamination not exist	
		1	Land/Sea contamination exist	
12	Surface Type	0	Sea	
		1	Land	
11	ON/OFF channel Flag	0	Channel is ON	
		1	Channel is OFF	
10	Level-0 Count error	0	No error	
		1	L0 count Saturated or L0 count poor value	
9	Level 0 hot or cold count error	0	No error	
		1	Error in cold or hot count	
8	Geo-location estimation	0	Good	
		1	Poor/Bad	
7 and 6	Calibration Flag	Bit 7	Bit6	
		0	0	Calibration is OK
		1	1	Calibration failure
		0	1	Degraded gain averaging
		1	0	Partial calibration
5 and 4	Complexity of TB correction	Bit5	Bit4	
		0	0	No correction
		0	1	Low
		1	0	Medium
		1	1	High
3	Interpolation quality	0	Good	
		1	Bad	
2	AGC/AOC loops	Bit = 1	Active	
		Bit =0	Inactive	



1-0 (LSB)	ICE Flag	Bit1	Bit0	
		0	0	ICE
		1	0	No ICE
		0	1	Spare
		1	1	Ice Map information is not available

*Table 4.3-3.11.1.a: Sample/Pixel quality flag for MADRAS*

Bit no.	Quality Flag Name	Quality Flag Bit applicability for different levels of products				Remarks
		L1A	L1A2	L1A3	L1B	
15	TB validity	L1A	L1A2	L1A3	L1B	
14	Sun Glint	L1A	L1A2	L1A3	L1B	
13	Land/Sea contamination	L1A	L1A2	L1A3	L1B	
12	Surface Type	L1A	L1A2	L1A3	L1B	
11	ON/OFF channel	L1A	L1A2	L1A3		
10	Level-0 Count Saturated/poor value	L1A				
9	Level 0 hot or cold count error	L1A	L1A2	L1A3		
8	Geo-location estimation	L1A	L1A2	L1A3	L1B	
7 and 6	Calibration Flag	L1A	L1A2	L1A3		
5 and 4	TB corrected	L1A	L1A2	L1A3		
3	Interpolation quality		L1A2	L1A3	L1B	
2	AGC/AOCC loop active	L1A	L1A2	L1A3		
1-0	ICE Flag	L1A	L1A2	L1A3	L1B	

*Table 4.3-3.11.1.B: Sample/Pixel quality flag Validity for MADRAS different levels of product*

#### 4.3.3.12.3.2 Sample/pixel/cell Quality Flag for SAPHIR in the levels L1A and L1A2, L1A3 & L1B product

The Sample/pixel quality flag is 16 bit unsigned integer parameter. Each bit of this parameter is assigned to different Quality flags which are listed in following table:

Bit no.	Quality Flag Name	Definition of bit values		
		Value	Bit definition	
15 (MSB)	TB validity	0	Valid	
		1	Invalid	
14	Sun Glint	0	Sun Glint not present	
		1	Sun Glint present	
13	Land/Sea contamination	0	Land/Sea contamination not exist	
		1	Land/Sea contamination exist	
12	Surface Type	0	Sea	
		1	Land	
11	ON/OFF channel Flag	0	Channel is valid	
		1	Channel is unvalid	
10	Level-0 Count Saturated	0	Not Saturated	
		1	Saturated	
9	Level-0 Count poor value	0	Count is ok - Able to generate TB	
		1	Count is poor - Unable to generate TB	
8	Geo-location estimation	0	Good	
		1	Poor/Bad	
7 and 6	Calibration Flag	Bit7	Bit 6	
		0	0	Calibration OK
		1	1	Calibration failure
		0	1	Degraded gain averaging
5	Hot count error	1	0	Partial calibration
		0		OK
4	Cold Sky count error	1		Error
		0		OK
3	Interpolation quality	1		Error
		0		Good
2	Blank	1		Bad
1-0 (LSB)	ICE Flag	0		
		Bit 1	Bit 0	
		0	0	ICE
		1	0	No ICE
		0	1	Spare

		1	1	Ice Map information is not available
--	--	---	---	--------------------------------------

*Table 4.3-3.11.3.2.a: Sample/Pixel quality flag for SAPHIR L1A and L1A2, L1A3 & L1B*

Bit no.	Quality Flag Name	Quality Flag Bit applicability for different levels of products				Remarks
		L1A	L1A2	L1A3	L1B	
15	TB validity	L1A	L1A2	L1A3	L1B	
14	Sun Glint	L1A	L1A2	L1A3	L1B	
13	Land/Sea contamination	L1A	L1A2	L1A3	L1B	
12	Surface Type	L1A	L1A2	L1A3	L1B	
11	ON/OFF channelFlag	L1A	L1A2			
10	Level-0 Count Saturated	L1A				
9	Level-0 Count poor value	L1A				
8	Geo-location estimation	L1A	L1A2	L1A3	L1B	
7and 6	Calibration Flag	L1A	L1A2	L1A3		
5	Hot count error	L1A				
4	Cold Sky count error	L1A				
3	Interpolation quality		L1A2	L1A3	L1B	
2	Blank					
1-0	ICE Flag	L1A	L1A2	L1A3	L1B	

*Table 4.3-3.11.3.2.b: Sample/Pixel quality flag Validity for SAPHIR different levels of product*

**4.3.3.12.3.3 Sample/pixel/cell Quality Flag for SCARAB in the levels L1A and L1A2, L1A3 & L1B products**

The Sample/pixel quality flag is 16 bit unsigned integer parameter. Each bit of this parameter is assigned to different Quality flags which are listed in following table:

Bit no.	Quality Flag Name	Definition of bit values	
		Value	Bit definition
15	Radiance validity	0	Valid
		1	Invalid
14	Blank	0	
13	Land/Sea contamination	0	Land/Sea contamination not exist
		1	Land/Sea contamination exist
12	Surface Type	0	Sea
		1	Land
11	ON/OFF channel flag	0	Channel is valid
		1	Channel is not valid
10	Level-0 Count Saturated	0	Not Saturated
		1	Saturated
9	Level-0 Count poor value	0	Count is ok - Able to generate Radiance
		1	Count is poor - Unable to generate Radiance
8	Geo-location estimation	0	Good
		1	Poor/Bad
7	Space count error	0	OK
		1	Error
6	Blank	0	
5	Blank	0	
4	Blank	0	
3	Interpolation quality	0	Good
		1	Poor/Bad
2	Gain_flag	0	Good
		1	Error
1-0	Blank	0	

*Table 4.3-3.11.3.3a: Sample/Pixel quality flag for SCARAB L1A and L1A2, L1A3 & L1B*

Bit no.	Quality Flag Name	Quality Flag Bit applicability for different levels of products				Remarks
		L1A	L1A2	L1A3	L1B	
15	Radiance validity	L1A	L1A2	L1A3	L1B	
14	blank					
13	Land/Sea contamination	L1A	L1A2	L1A3	L1B	
12	Surface Type	L1A	L1A2	L1A3	L1B	
11	ON/OFF channel flag	L1A	L1A2			
10	Level-0 Count Saturated	L1A	L1A2			
9	Level-0 Count poor value	L1A	L1A2			
8	Geo-location estimation	L1A	L1A2	L1A3	L1B	
7	Space count error	L1A	L1A2			
6	Blank					
5	Blank					
4	Blank					
3	Interpolation		L1A2	L1A3	L1B	
2	Gain flag	L1A	L1A2			
1-0	Blank (ice flag)			L1A3		

Table 4.3-3.11.3.3.b: Sample/Pixel quality flag Validity for SCARAB different levels of product

#### 4.3.3.13 Definition of some attribute in L1 products

The Satellite configuration attribute is a 6bits array containing the following information :

Bit 5 (MSB)	Bit 4	Bit 3	Bit 2 /1/0(LSB)
SL configuration of the first scan (Backward=0 , Forward=1)	Instrument mode change during the orbit or segment wise file (0=No change, 1=change)	Satellite mode change during the orbit or segment wise product(0=No change, 1=change)	Satellite Mode of first scan (refer to table section 4.3)

C.N.E.S./ I.S.R.O.	<h1>Megha-Tropiques</h1>	Réf. TRO-0-ST-1610-CNES Ed: 3 Date: Jan17th 2013 Issue : 4 Page : 46
--------------------	--------------------------	---

## 5 FORMATTING CONVENTIONS

### 5.1 FORMAT FOR L1 PRODUCT

The MT Level-1 orbit-wise or segment-wise products will be archived in *HDF5* format version 5-1.6.4. The *HDF* is a common data format that has been developed to aid scientists and programmers in storing, transfer and distribution of datasets (products) which are created on various machines and with different software. It also refers to a collection of software, application interfaces, and utilities that comprise the *HDF* library and allows users to work with *HDF* files.

*HDF* is designed by the US National Centre for Supercomputing Application (NCSA) in 1988 and freely available function library by the same name with a set of command line utilities. *HDF* having the properties like self describe-ability, extensibility, versatility, flexibility, portability, standardization and most important is that it is available in public domain.

#### Data dissemination in HDF format :

*HDF* is a multi-object file format for sharing scientific data in a distributed environment. *HDF* was designed to address many requirements for storing scientific data, including:

- (a) *Support for the types of data and metadata commonly used by scientists*
- (b) *Efficient storage of and access to large data sets*
- (c) *Platform independence*
- (d) *Extensibility for future enhancements and compatibility with other standard formats*

*HDF files are self-describing. The term “self-description” means that, for each HDF data structure in a file, there is comprehensive information about the data and its location in the file. This information is often referred to as metadata. Also, many types of data can be included within an HDF file. For example, it is possible to store symbolic, numerical and graphical data within an HDF file by using appropriate HDF data structures.*

#### 5.1.1 Megha-Tropiques Data products Distribution requirements

Data Products of *MEGHA-TROPIQUES* mission are global in nature and is likely to be provided to registered users on internet. A data storage and retrieval system should bear the following features:

1. *Support for a Scientific Data and Meta data* : Storage of *MT* data requires support for extremely large and complex datasets and various datatypes. Metadata, supplementary data that describes the basic data, includes information such as the dimensions of an array, the datatype of the elements of the record etc
2. *Support for a range of hardware platform* : The Hyper Spectral Imager data can be originated from any one machine only to be used later on many different machines. So the aim is to help user’s to access data and meta data on as many hardware platforms as possible
3. *Support for range of software tools* : Variety of tools, utilities and range of library for reading, writing, searching, analyzing, archiving and transporting the data and metadata are required

The all above features are supported by the HDF freeware library. *HDF-5.1.6.3 released in 2004*, has been used as a reference for reading and writing of formats of *MT* data products.

C.N.E.S./ I.S.R.O.	<h1>Megha-Tropiques</h1>	Réf. TRO-0-ST-1610-CNES Ed: 3 Date: Jan17th 2013 Issue : 4 Page : 47
--------------------	--------------------------	---

### 5.1.2 Basic Elements of HDF5 :

*HDF5* file appears to the user as a directed graph. The hierarchical structure is represented through nodes of this graph as the higher-level HDF5 objects which are two primary structures: groups and datasets. Beside that each can have associated attributes which are a user-defined HDF5 structure to provide extra information about an HDF5 object..

- *HDF5 Group* : A mechanism of describing collection of related object designated as grouping structure, containing zero or more groups or datasets, together with supporting metadata. It has two parts, namely, group header (contains a group name and list of group attributes.) and group symbol table(list of the HDF5 objects belong to the group).
- *HDF5 Datasets* : A dataset is a multidimensional array of data elements, together with supporting metadata. It contains a header and a data array. There are four essential classes of information in any header viz. name, datatype, dataspace and storage layout.
- *HDF5 Data types*: HDF5 allows following datatypes viz.,
  - a. *Automatic data type*: it includes integer, float, floating point numbers, date, time, string, bit field and opaque. Each automatic data type belongs to a particular class and has several properties: size, order, precision and offset.
  - b. *Native data type*: these are C-like datatypes that are generally supported by the hardware of the machine on which the library was compiled.
  - c. *Compound data type*: it represents the collection of several datatypes in a single unit, similar to a struct used in C. The parts of compound data types are called members.
  - d. *Named data type* : It is used to share the datatype of a dataset with different datasets which are not defined in HDF library.
- *HDF5 Dataspace*: The dataset dataspace describes the dimensionality of the dataset. The dimensions of a dataset can be fixed or unlimited or extendible. The properties of dataspace represents the rank(number of dimensions) of the data array, the actual sizes of the dimensions of the array and the maximum sizes of the dimensions of the array.
- *HDF5 storage layout*: The *HDF5* format makes it possible to store data in three ways, (i) contiguous (ii) compact storage & (iii) chunked storage.
- *HDF5 Attribute*: Attributes are the small data objects describing the nature and/or intended usage of a primary data object, which may be a dataset, group, or named datatype. It has two parts (i) name and (ii) value. The value part contains one or more data entries of the same datatype.

A typical structure of *HDF5* objects in *HDF5* formatted file is pictorially depicted in *Figure 5.1.2-1: HDF5 objects in HDF5 file*

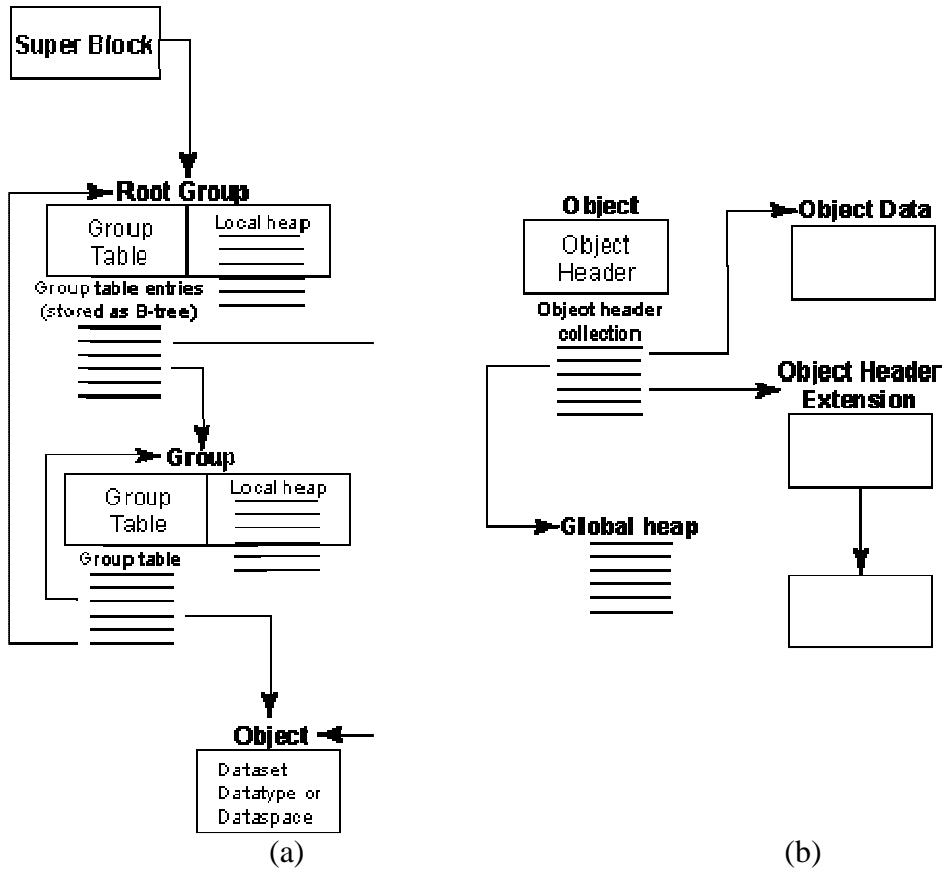

Figure 5.1.2-1: HDF5 objects in HDF5 file

(a) Relationship between root group, other group and objects.

(b) HDF5 objects- datasets, datatypes or dataspace



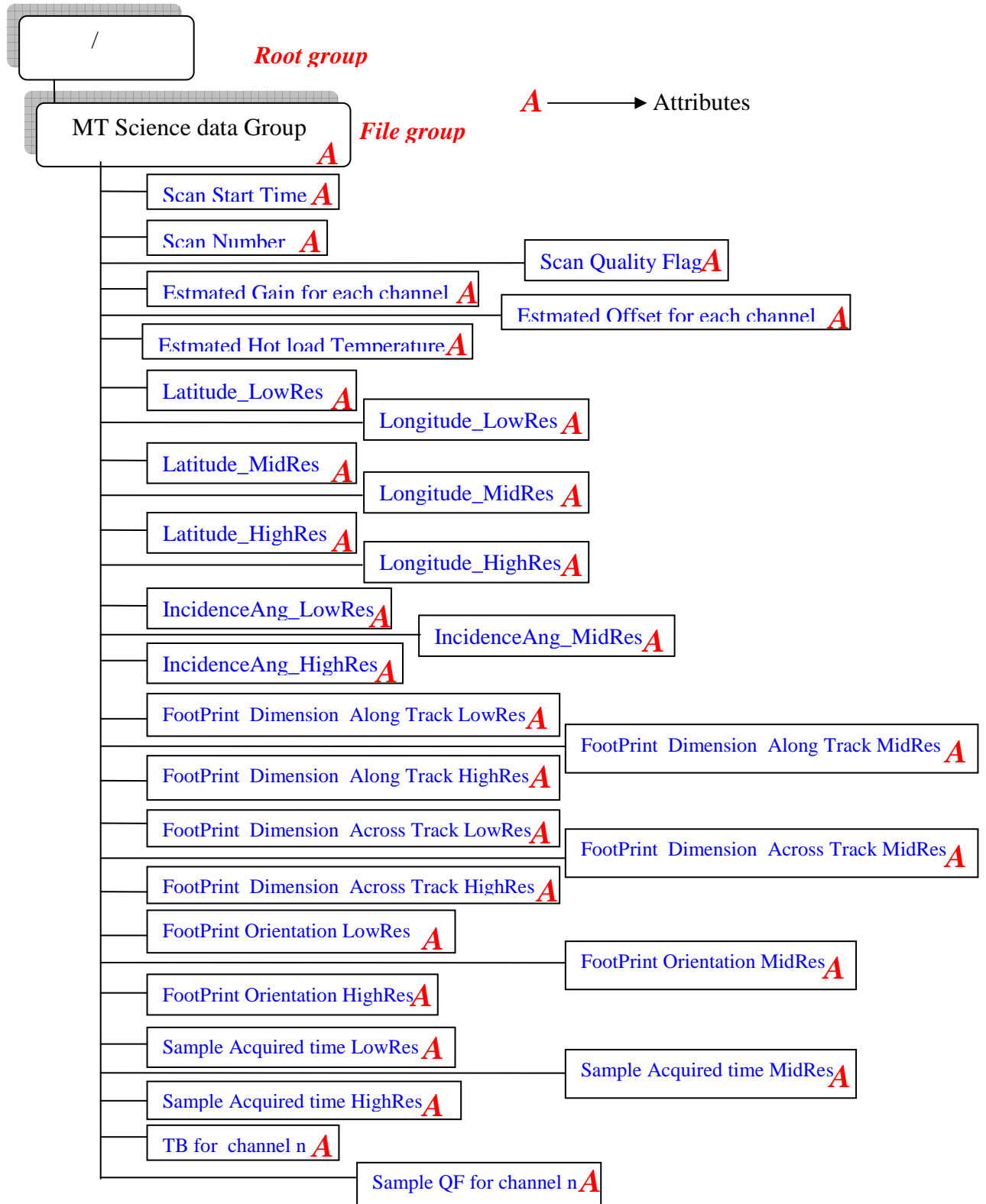

Figure 5.1.2-2: MT HDF5 file

### 5.1.3 MT Level-1 file structure

The structure of archived MT Level-1 product file will have a “Science Data Group” within file root group. The Science Data Group will contain all the datasets related to Level-1 product parameters. The datasets are two dimensional or one dimensional array.

The Science Data Group will have few attributes, which are to provide information about the product, they can have different data types namely string type, short integer type etc. Each dataset also can have few attribute which provides additional information about the physical parameter associated with the dataset e.g. valid range of parameter, units of parameter, fill value of dataset, numeric range of dataset, scale factor to convert dataset numeric values to the physical parameter values etc. The layout of Level-1 product file is shown in figure: 5.1.3.1 as an example of MADRAS Level-1A structure.

## 5.2 DATA TYPE CONVENTIONS

The following conventions are used in the format description.

HDF5 data type	C data type	Description	Valid range
H5T_STD_I8LE	Char	8-bits (1-byte) signed char	-128 to +127
H5T_STD_I16LE	Short Integer	16-bits(2-bytes) signed integer	-32768 to +32767
H5T_STD_I32LE	Integer	32-bits (4-bytes) signed integer	-2147483648 to +2147483647
H5T_STD_U8LE	Unsigned Char	8-bits (1-byte) unsigned char	0 to 257
H5T_STD_U16LE	Unsigned short integer	16-bits (2-bytes) unsigned integer	0 to 65535
H5T_STD_U32LE	Unsigned integer	32 Bits (4 bytes ) signed integer	0 to 4294967296
H5T_IEEE_F32LE	Float	32-bits (4-bytes) floating-point integer	-1,4 *10-45 to 3,4*10+38
H5T_IEEE_F64LE	Double	64-bits (8-bytes) floating-point integer	-4,9 *10-324 to 1,7 *10+308
H5T_C_S1	Char[]	Array of 8-bit character (string)	

Table 5.2-1: Data type conventions

### 5.3 FILE NAMING CONVENTION

The proposed filename conventions for various levels of data products orbit wise/ segment wise are as follows:

Level	Product type	Product File Name
1A	NRT (Segment wise)	MT1SSSSL1A_X.XX_VVV_I_II_L_YYYY_MM_DD_HH_mm_ss_YYYY_MM_DD_HH_mm_ss_NNNNN_MMMMM_CCC_TT_UU_STN_SG.h5
	Standard (Orbit wise)	MT1SSSOL1A_X.XX_I_II_L_YYYY_MM_DD_CCC_TT_OOOOO.h5
1A2	NRT (Segment wise)	MT1SSSSL1A2_X.XX_VVV_I_II_L_YYYY_MM_DD_HH_mm_ss_YYYY_MM_DD_HH_mm_ss_NNNNN_MMMMM_CCC_TT_UU_STN_SG.h5
	Standard (Orbit wise)	MT1SSSOL1A2_X.XX_VVV_I_II_L_YYYY_MM_DD_CCC_TT_OOOOO.h5
1A3	NRT (Segment wise)	MT1SSSSL1A3_X.XX_VVV_I_II_L_YYYY_MM_DD_HH_mm_ss_YYYY_MM_DD_HH_mm_ss_NNNNN_MMMMM_CCC_TT_UU_STN_SG.h5
	Standard (Orbit wise)	MT1SSSOL1A3_X.XX_VVV_I_II_L_YYYY_MM_DD_CCC_TT_OOOOO.h5
1B	NRT (Segment wise)	MT1SSSSL1B_X.XX_VVV_I_II_L_YYYY_MM_DD_HH_mm_ss_YYYY_MM_DD_HH_mm_ss_NNNNN_MMMMM_CCC_TT_UU_STN_SG.h5
	Standard (Orbit wise)	MT1SSSOL1B_X.XX_VVV_I_II_L_YYYY_MM_DD_CCC_TT_OOOOO.h5

Table 5.3-1: Filename convention

Where:

- (a) MT1 : Megha –Tropiques
- (b) SSS: Indicates the Sensor Name “MAD”/“SAP”/“SCA” for MADRAS, SAPHIR & SCARAB respectively
- (c) O/S: Indicates the data is standard (Orbit –wise)/ NRT(Segment-wise) product type
- (d) Product type : L1A,L1A2, L1A3 or L1B

Remark: As MADRAS L1A2 and L1A3 are identical, for that case, the “L1A2” label will be indicated in the file name

- (e) X.XX indicates the software version.
- (f) VVV: is an extension for software which will be frozen to 000 for operational software but will be significant for validation Software
- (g) I\_II indicates the IODD version . The version will change if version of any IODD file will change example 9\_07
- (h) L indicates the origin of processing I/C for ISRO or CNES
- (i) YYYY: The calendar year when first sample of  $I^{st}$  Record of data was acquired
- (j) MM: The month of the year when first sample of the  $I^{st}$  Record of data was acquired
- (k) DD: The date of the year when first sample of the  $I^{st}$  Record of data was acquired

C.N.E.S./ I.S.R.O.	<b>Megha-Tropiques</b>	Réf. TRO-0-ST-1610-CNES Ed: 3 Date: Jan17th 2013 Issue : 4 Page : 52
--------------------	------------------------	---

- (l) HH\_mm\_ss : Hour, minutes, second of first sample /pixel of first record of data
- (m) YYYY: The calendar year when first sample of *last* record of data was acquired
- (n) MM: The month of the year when first sample of the *last* record of data was acquired
- (o) DD: The date of the year when first sample of the *last* record of data was acquired
- (p) HH\_mm\_ss : Hour, minutes, second of first sample /pixel of last record of data
- (q) NNNNN: Orbit start number no. of the first sample of the *first* Record
- (r) MMMMM: Orbit end number : no. of the last sample of the last Record acquired
- (s) CCC : Index of the orbit cycle (a cycle is 7 days)and corresponds to orbit of first scan
- (t) TT: First scan Cycle number : Relative orbit in the cycle for the first record ( 1 to 97)
- (u) UU: last scan Cycle number : Relative orbit in the cycle for the last record ( 1 to 97)
- (v) STN : Ground station name : KRU, HBK,BL1 or BL2
- (w) SG : segment number copied from L0 file name , only for NRT products
- (x) OOOOO: Satellite orbit no. of archived orbit wise product

Remark :

For MADRAS , date for first and last samples of 18,7Ghz polarisation H channel will be considered.

For SCARAB , date of first and last sample of Solar channel will be considered.

Using this convention, sample product names for 25<sup>th</sup> December 2009 and orbit no. 12345 is shown in Table as follows with time of first record sample of the dump equal to 02H50mn01sec and time of last record equal to 03H40mn20sec

Cycle number is : 91 and first and last cycle number are 85 and 86 . Ground station is BangaloreN°1: BL1 and Segment number is SG=01

Table : File naming convention for MT Payload products	
Product Level	Product File Name
Level1A (segment wise)	MT1MADSL1A__1.00_000_9_07_I_2009_12_25_02_50_01_2009_12_25_03_40_20_12345_12346_091_85_86_BL1_01.h5
Level1A2 (segment wise)	MT1MADSL1A2__1.00_000_9_07_I_2009_12_25_02_50_01_2009_12_25_03_40_20_12345_12346_091_85_86_BL1_01.h5
Level1A3 (segment wise)	MT1MADSL1A3__1.00_000_9_07_I_2009_12_25_02_50_01_2009_12_25_03_40_20_12345_12346_091_85_86_BL1_01.h5
Level1B (segment wise)	MT1MADSL1B__1.00_000_9_07_I_2009_12_25_02_50_01_2009_12_25_03_40_20_12345_12346_091_85_86_BL1_01.h5
Level 1A (orbit wise)	MT1SAPOL1A__1.00_000_9_07_I_2009_12_25_85_091_12345.h5
Level 1A2 (orbit wise)	MT1SAPOL1A2__1.00_000_9_07_I_2009_12_25_85_091_12345.h5
Level 1A3 (orbit wise)	MT1SAPOL1A3__1.00_000_9_07_I_2009_12_25_85_091_12345.h5
Level 1B (orbit wise)	MT1SCAOL1B__1.00_000_9_07_I_2009_12_25_85_091_12345.h5

*Table 5.3-2: Example of a filename*

#### 5.4 PRODUCT IDENTIFICATION CODE

The Product Identification code is filename without file extension “.h5”. Using this convention, data products identification code for the various levels of products (orbit wise/ segment wise) generated for samples acquired on data 25th December 2009 in orbit no. 12345 – 12346 are shown in Table as follows

Table : Product Identification code for MT Payload products		
Dissemination type	Product Level	Product Identification code
Segment wise	Level 1A	MT1MADSL1A__1.00_000_9_07_I_2009_12_25_02_50_01_200_9_12_25_03_40_20_12345_12346_091_85_86_BL1_01
	Level 1A2	MT1MADSL1A2_1.00_000_9_07_I_2009_12_25_02_50_01_2009_12_25_03_40_20_12345_12346_091_85_86_BL1_01
	Level 1A3	MT1MADSL1A3_1.00_000_9_07_I_2009_12_25_02_50_01_2009_12_25_03_40_20_12345_12346_091_85_86_BL1_01
	Level 1B	MT1MADSL1B__1.00_000_9_07_I_2009_12_25_02_50_01_2009_12_25_03_40_20_12345_12346_091_85_86_BL1_01
Orbit wise	Level 1A	MT1SAPOL1A__1.00_000_9_07_I_2009_12_25_85_091_12345
	Level 1A2	MT1SAPOL1A2_1.00_000_9_07_I_2009_12_25_85_091_12345
	Level 1A3	MT1SAPOL1A3_1.00_000_9_07_I_2009_12_25_85_091_12345
	Level 1B	MT1SCAOL1B__1.00_000_9_07_I_2009_12_25_85_091_12345

Table 5.4-1: Example of a product identification code

#### 5.5 DATA COMPRESSION

No data compression is applied to the data

## 6 DETAILED DEFINITION OF L1 PRODUCTS

### 6.1 DEFINITION OF L1A PRODUCTS

- ⇒ This product L1A consists in generating brightness temperature (MADRAS/SAPHIR) or radiance (SCARAB) of the samples acquired on board in the instrument geometry along with geo-location, time of acquisition, and other relevant parameters and flags
- ⇒ Data is time tagged and geo-located.
- ⇒ Radiometric corrections (calibration factors) are applied on each sample.
- ⇒ Data are processed independently for each instrument
- ⇒ The product will be available as standard product and NRT product
- ⇒ Product will contain only complete scans

#### 6.1.1 MADRAS L1A products definition

- ◆ Data will be processed independently per frequency channel 18,23,36, 89 and 157Ghz and per scan line, assuming that H & V channels of the same frequency have to be processed jointly to apply radiometric corrections (cross polarization)
- ◆ The L1A product is provided in the instrument geometry.
- ◆ The acquired geometry sample is dynamic, following scan geometry, orbit & attitude variations and other parameters
- ◆ All samples generated on board are processed for this product, even samples which are acquired over  $\pm 65^\circ$ . Limits are identified in the table section 3.1
- ◆ Along a scan line, samples of HF (157GHz), MF (89GHz) or LF (18/23/36GHz) channels are not collocated and do not have the same footprint size.
- ◆ As the samples of LF channels 18,23 and 36GHz are collocated, the latitude/longitude information is the same for the 5 channels
- ◆ The centre of the sample correspond the middle of the integration time.
- ◆ The shape of the sample footprint is an ellipse. Approximate dimensions are the following :

Sample Dimension	HF Channel (157GHz)	MF Channel (89GHz)	LF channels (18/23/36GHz )
Along track	10,1 Km	16,81Km	67,25Km
Across track	6.0 Km	10,0Km	40,0Km

Table 6.1-1: MADRAS footprint

- ⇒ Data are processed per scan line. Nevertheless, some calibration parameters are calculated using various consecutive scans

### 6.1.1.1 Content of MADRAS L1A file

- ◆ The following information will be included in the L1A file

See excel document [ProductDefinition\\_MADRAS\\_L1A-1-1-2-3-B\\_HDFMGTStructure\\_13rev2.xls](#)

### 6.1.2 SAPHIR L1A products definition

- ⇒ Data will be processed independently per channel except some calibration parameters which will be calculated over many scans
- ⇒ Due to SAPHIR geometry, 182 samples per scan line and per channels (6 channels) are processed.
- ⇒ Along the scan line, samples of all the 6 channels are collocated and have exactly the same footprint dimensions projected on ground as well the same geo-location.
- ⇒ Due to over-sampling of pixels by a factor of 1, 4 along the scan line, the following samples geometry is obtained .It can be noted that consecutive samples are overlapped

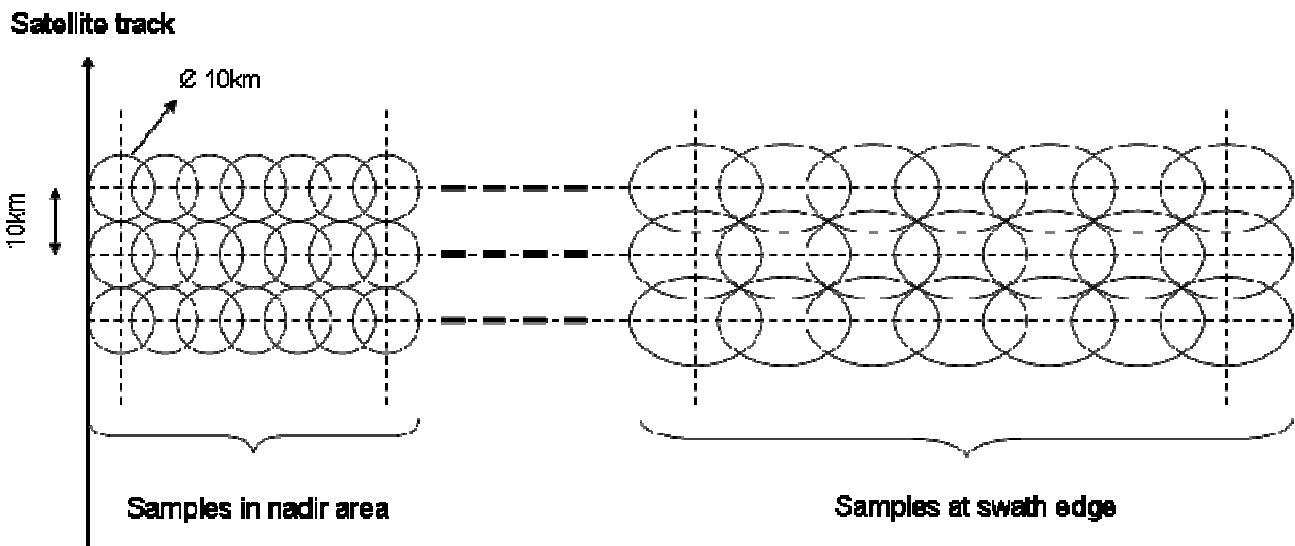

Figure 6.1-1: "Sample" geometry of Level 1-A product of SAPHIR

- ⇒ Footprints are elliptical in shape and footprint sizes are as follows :

Sample size on ground	Across track	Along track
At Nadir	10Km	10km
At the edge of the swath	22,7 Km	14,5 Km



Table 6.1-2: SAPHIR footprint

- ◆ In the L1 product, the centre of 182 samples footprints will be geo-located and time tagged. The footprint centre correspond to the middle of the integration time.
- ◆ The acquired geometry sample is dynamic, following satellite attitude variation.
- ◆ Data are processed per scan line. Nevertheless, some calibration parameters are calculated using a few consecutive scan lines

### 6.1.2.1 Content of SAPHIR L1A file

- ◆ The following information will be included in the SAPHIR L1A file

See excel document ProductDefinition\_SAPHIR\_L1A-1-1-2-3-B\_HDFMGStructure\_13rev2.xls

### 6.1.3 SCARAB L1A products definition

- ◆ Data will be processed independently per channel and per scan line. However, some calibration parameters are determined using various consecutive scans.

### Scanning pattern on ground

The following figure shows the IFOV footprints and the sampling of the earth surface (values on the figure correspond to current nominal calculated values and are provided for information only).

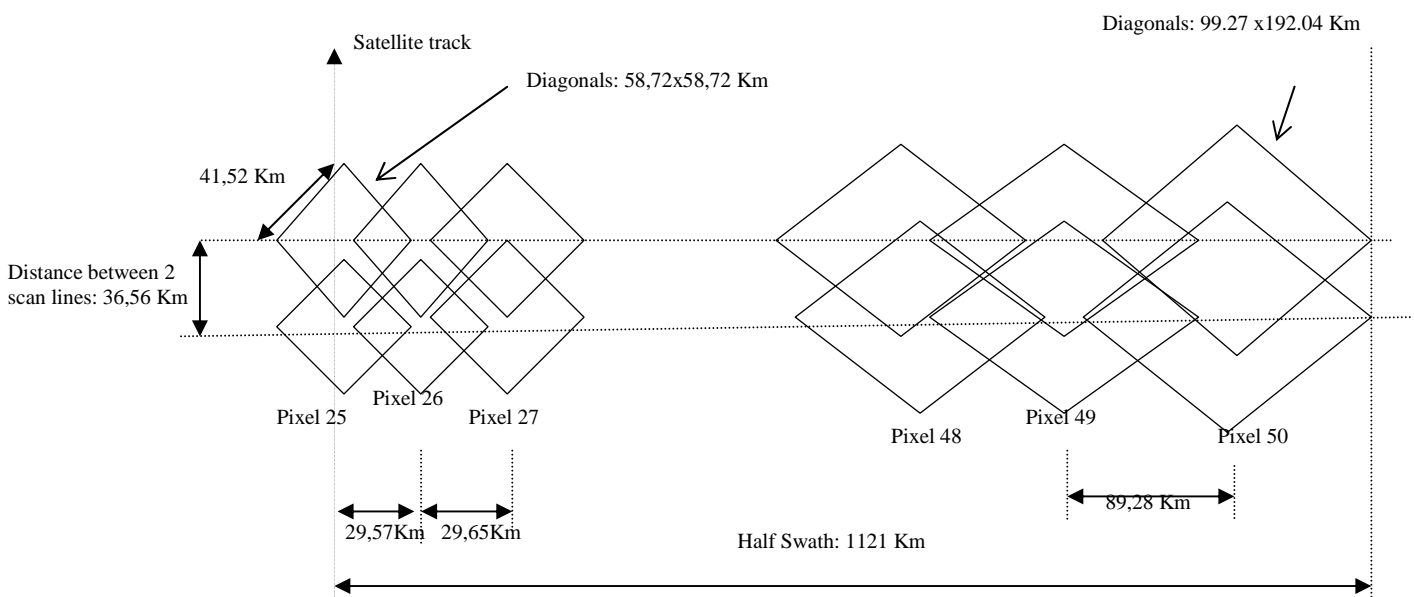

Figure 6.1-2: "Sample" geometry of Level 1-A product of SCARAB

C.N.E.S./ I.S.R.O.	<h1>Megha-Tropiques</h1>	Réf. TRO-0-ST-1610-CNES Ed: 3 Date: Jan17th 2013 Issue : 4 Page : 58
--------------------	--------------------------	---

- ◆ The sample center is located in the middle of the integration time.
- ◆ 51 samples per channels and 3 samples for cold sky for each channels during scan.
- ◆ The acquired geometry sample is dynamic, following satellite attitude variation.
- ◆ Data are processed per scan line. Nevertheless, some calibration parameters are calculated using a few consecutive scan lines.
  
- ◆ In fact, the location of the 51 measured radiances values will be calculated at the top of the atmosphere : 20km above the surface and also at the surface.

### 6.1.3.1 Content of L1A SCARAB File

The content is described in the following document :

See excel document [ProductDefinition\\_SCARAB\\_L1A-1-1-2-3-B\\_HDFMGStructure\\_13rev2.xls](#)

## 6.2 GENERAL DEFINITION OF L1 A2 PRODUCTS

- ◆ This product L1A2 consists in generating brightness temperature of pixels for MADRAS and SAPHIR radiometers. Pixels are defined as non overlapping synthetic footprints covering the scan swath. (Refer to section 3).
- ◆ For each instrument, using the instrument radiometric samples (L1A data), re-sampling of L1A data along the scan is performed to generate pixels.
- ◆ Pixels are provided in the instrument geometry.
- ◆ Data are time tagged and geo-located.
- ◆ Data are processed independently for each instrument
- ◆ The product will be available as standard product and NRT product.

### 6.2.1 Definition of MADRAS L1A2 product

- ◆ Data are processed independently per scan line.
- ◆ The re-sampling of L1A data is performed in order to provide on each scan line, collocated pixels for all the channels taking as a reference the actual position of MADRAS 89Ghz pixels. MADRAS other channels data pixel centers shall be located at the exact location of 89GHz MADRAS pixels centers.



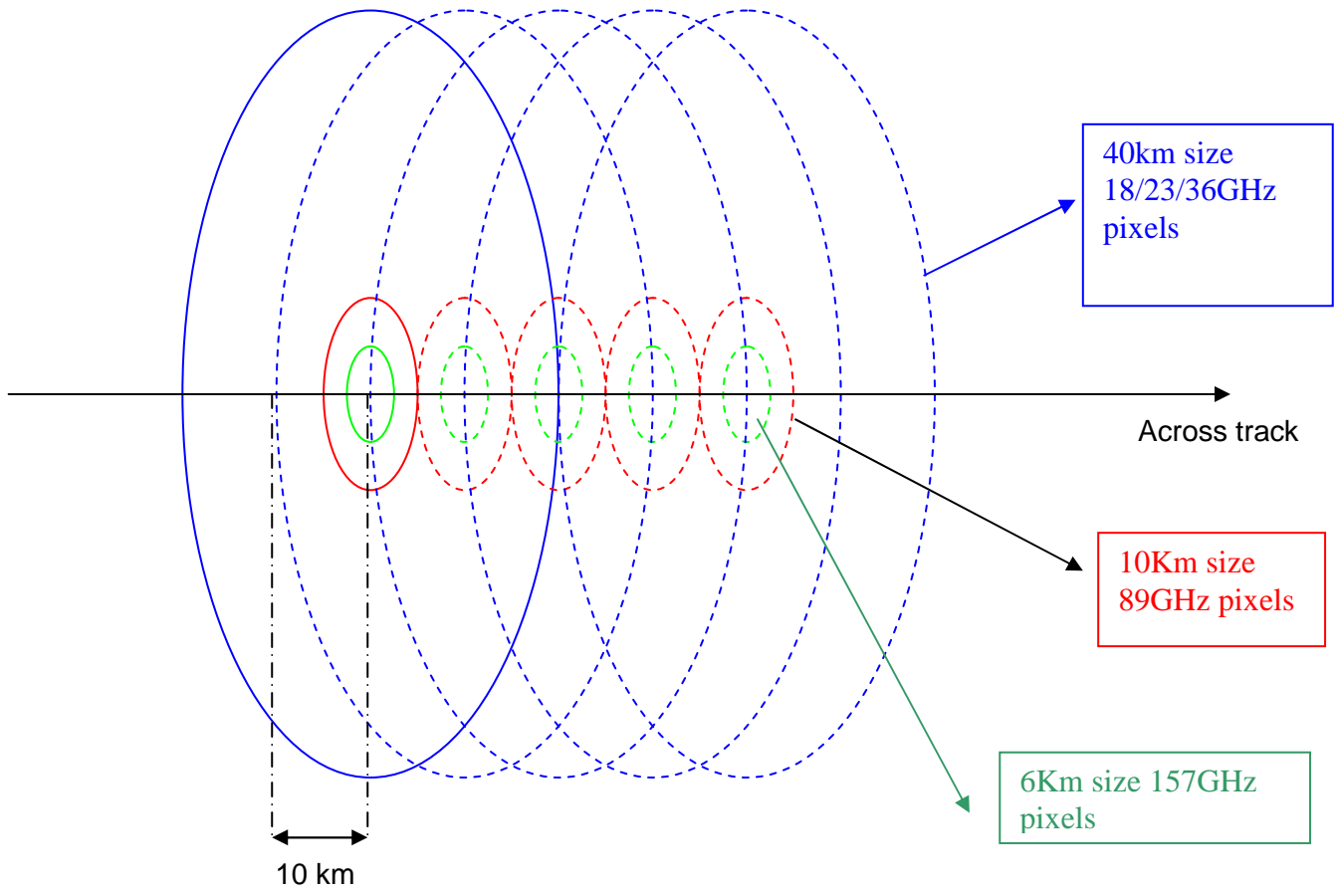

Figure 6.2-2: Pixel resolution on the ground of MADRAS

### 6.2.1.1 Content of MADRAS L1A2 file

- ◆ The following information will be included in the L1A2 file:  
See excel document [ProductDefinition\\_MADRAS\\_L1A-1-1-2-3-B\\_HDFMGTSstructure\\_13rev2.xls](#)

### 6.2.2 Definition of SAPHIR L1A2 product

- ◆ The re-sampling of L1A data (182 samples) is performed in order to provide on each scan line 130 pixels for all the channels as defined in the hereafter specified geometry.
- ◆ Data will be processed independently per channel.
- ◆ Data are processed independently per scan line.
- ◆ The brightness temperature of each pixel is obtained by averaging brightness temperature of neighbored samples of the same scan line.
- ◆ Example (the figure doesn't represent the exact SAPHIR configuration):

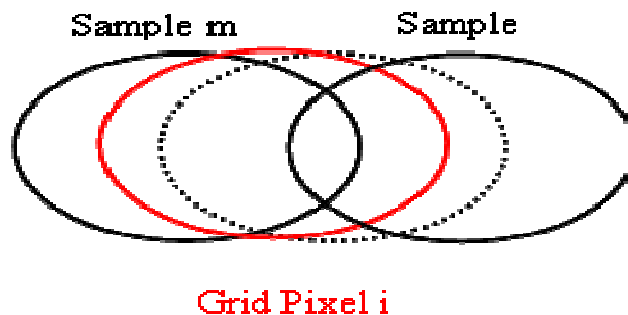

*Figure 6.2-3: Example of re-sampling of SAPHIR*

- ◆ The proposed pixel grid is a dynamic grid following actual satellite attitude variations.

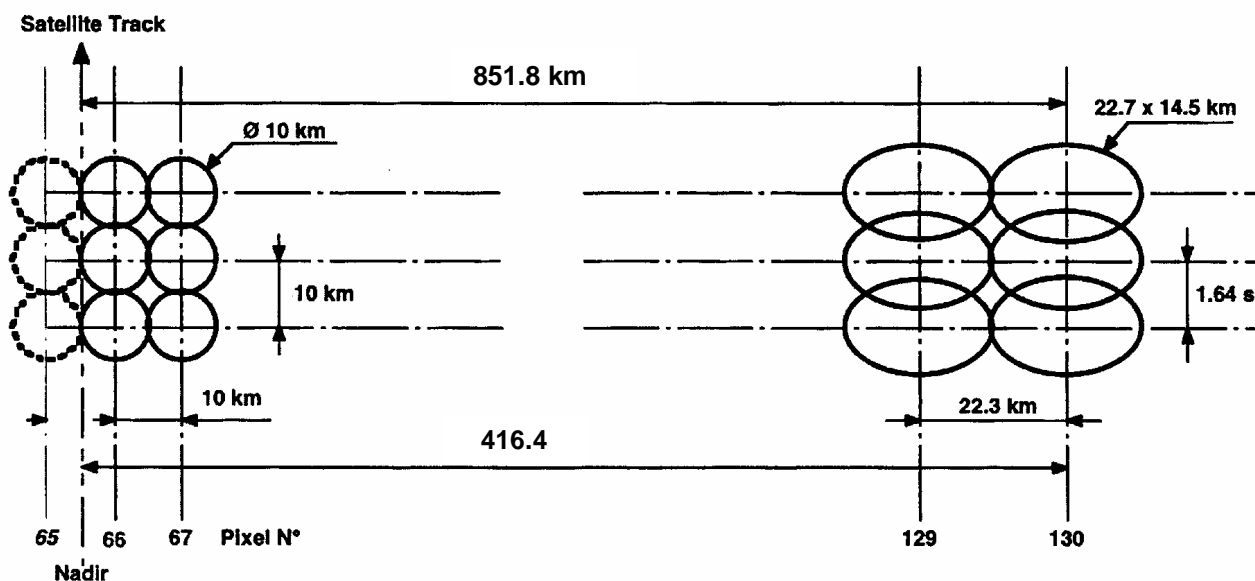

Figure 6.2-4: Pixel representation on the ground of SAPHIR

- ◆ It can be noted that pixels are contiguous across track, and also along track at Nadir. Due to the definition of pixels (antenna IFOV), pixels across track are contiguous but some overlap exist in the along track direction.
- ◆ The pixels sizes are varying along the swath as presented in *Table 6.1-2: SAPHIR footprint*.

#### 6.2.2.1 Content of SAPHIR L1A2 file

- ◆ The following information will be included in the L1A2 file:

See excel document [ProductDefinition\\_SAPHIR\\_L1A-1-1-2-3-B\\_HDFMGTStructure\\_13rev2.xls](#)

#### 6.2.3 Definition of Scarab L1A2 products

The L1A2 product for Scarab is identical to L1A except that some algorithm optimisation is proposed to improve the registration of channels.

#### 6.2.4 Content of SCARAB L1A2 file

See excel document [ProductDefinition\\_SCARAB\\_L1A-1-1-2-3-B\\_HDFMGTStructure\\_13rev2.xls](#)

### 6.2.5 Definition of L1A3 PRODUCTS: based ON 89GHZ MADRAS grid

- ⇒ In order to facilitate the combined use of the whole set of the 3 instruments data, projection of SAPHIR, SCARAB pixels and all MADRAS pixels is performed in the conical scan 89GHz MADRAS Grid .
- ⇒ Data are interpolated from L1A for SCARAB and L1A2 for SAPHIR inside a fixed grid related to the current orbit and defined by the location of MADRAS 89GHz pixels.

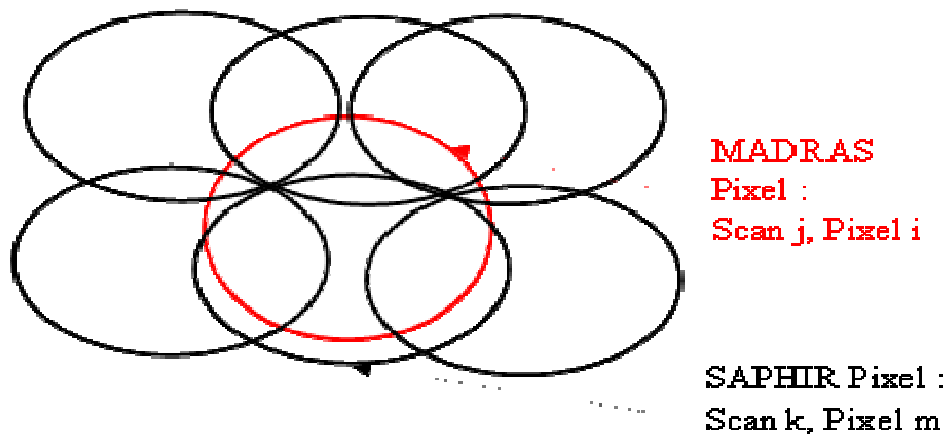

Figure 6.2-5: Example for SAPHIR

- ⇒ This product is generated for MADRAS, SAPHIR and SCARAB data separately, knowing that acquisition of SAPHIR , MADRAS and SCARAB data are not synchronous.
- ⇒ The 89 GHz grid is a dynamic grid, following satellite attitude variations.
- ⇒ The swath of this product is limited to MADRAS swath that is to say about 1700 Km.
- ⇒ The grid is based on conical scan geometry- A grid line is composed of 214 elements equal to the valid number of 89GHz “10km size pixels centres”.
- ⇒ As per the L1A2, MADRAS other channels data pixel centres shall be located at the exact location of 89GHz MADRAS pixels centres. Subsequently, 157 GHz and 18/23./36 GHz pixels are re-sampled in the 89 GHz grid. The size of the other channels (157 GHz and 18/23/36 GHz) re-sampled pixels is the same as the size of original scan line pixels.
- ⇒ MADRAS L1A3 data are identical to L1A2 data.

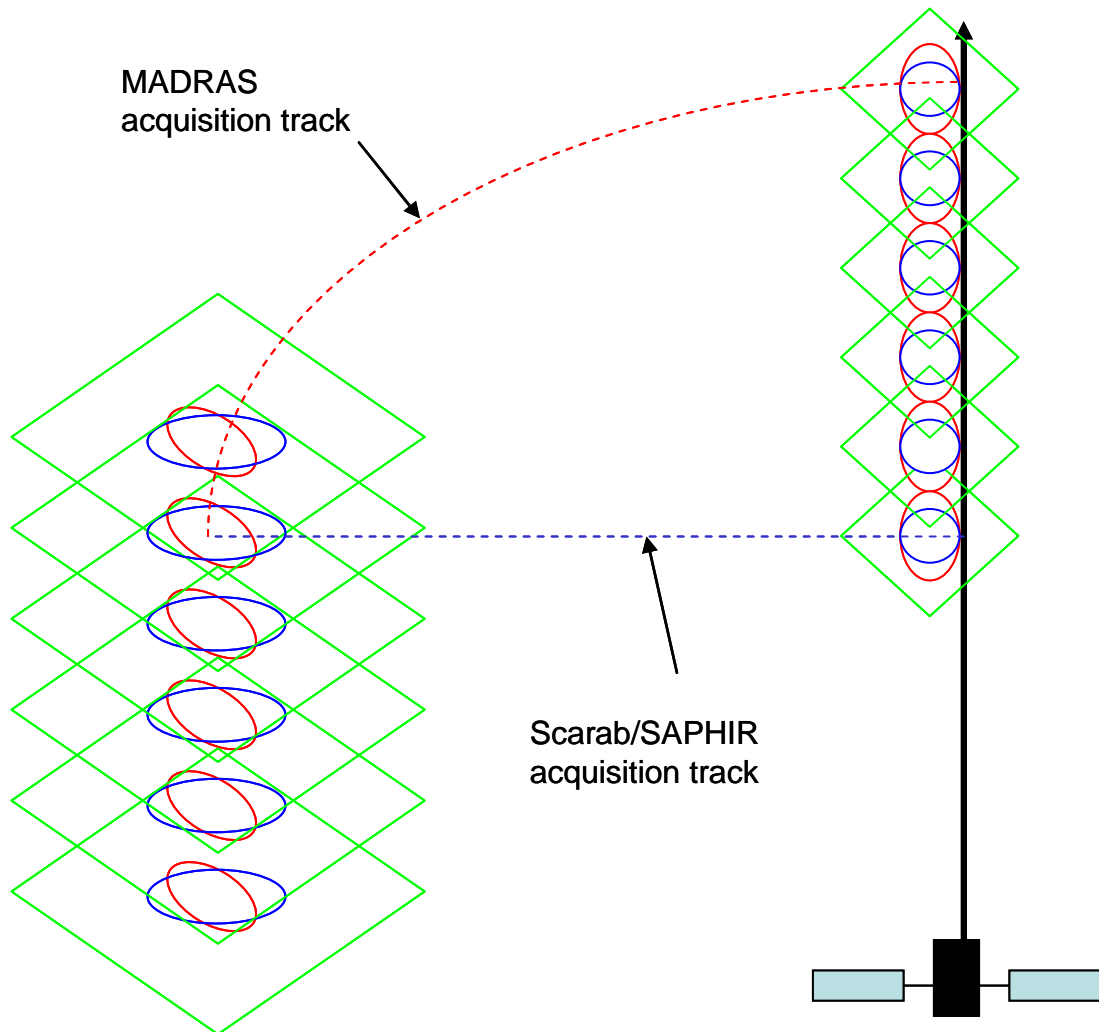

Figure 6.2-6: Pixel representation on ground of the 3 instruments

- ◆ MADRAS Pixels shape is an ellipse for all channels... Dimensions are given below :

MADRAS pixel size : ellipse shape	89 GHz	157 GHz	18/23./36 GHz
Across scan typical value	10km	6Km	40Km
Along scan typical value	16,81Km	10,1Km	67,25Km

Table 6.2-1: MADRAS pixel size

- ◆ SAPHIR and SCARAB data pixel centres are located at the exact location of 89 GHz MADRAS pixels centres.
- ◆ Processing of SAPHIR and SCARAB re-projection will require at first, processing of MADRAS 89GHz earlier scans.



C.N.E.S./ I.S.R.O.	<h1>Megha-Tropiques</h1>	Réf. TRO-0-ST-1610-CNES Ed: 3 Date: Jan17th 2013 Issue : 4 Page : 65
--------------------	--------------------------	---

- ◆ It should be noted that up to 2 minutes delay in acquisition can exist between SAPHIR and MADRAS footprints corresponding to the same location on the grid.
- ◆ Datation of MADRAS channels is computed from the formula given in section 4.3.3.10.
- ◆ For SAPHIR/SCARAB, datation will be computed using the date of the original L1A2/L1A pixels or samples participating in the L1A3 pixel generation... Interpolation using the 4 closest samples /pixels will be implemented for datation estimate.
- ◆ Similarly, the following information related to SCARAB : viewing zenith angle, solar viewing angle, relative azimuth angle will be calculated interpolation using the 4 closest samples (TBC).

The L1A3 product format shall include the following:

## 6.2.6 MADRAS L1A3 product

### 6.2.6.1 Content of L1A3 MADRAS file

The format is described in the following document :

See excel document [ProductDefinition\\_MADRAS\\_L1A-1-1-2-3-B\\_HDFMGStructure\\_13rev2.xls](#)

## 6.2.7 SAPHIR L1A3 product

### 6.2.7.1 Content of SAPHIR L1A3 file

The format details are described in the following document:

See excel document [ProductDefinition\\_SAPHIRS\\_L1A-1-1-2-3-B\\_HDFMGStructure\\_13rev2.xls](#)

## 6.2.8 SCARAB L1A3 product

### 6.2.8.1 Content of SCARAB L1A3 file

The format details are described in the following document:

See excel document [ProductDefinition\\_SCARAB\\_L1A-1-1-2-3-B\\_HDFMGStructure\\_13rev2.xls](#)

C.N.E.S./ I.S.R.O.	<h1>Megha-Tropiques</h1>	Réf. TRO-0-ST-1610-CNES Ed: 3 Date: Jan17th 2013 Issue : 4 Page : 66
--------------------	--------------------------	---

### 6.3 DEFINITION OF LIB PRODUCTS: BASED ON GEOMETRIC SWATH GRID

- ◆ Level 1B is defined for payload specific (MADRAS, SAPHIR & SCARAB) products. The L1B product contain the brightness temperature or radiance of the sensors interpolated onto a static grid
- ◆ It should be noted that MADRAS, SAPHIR, SCARAB acquisition are not synchronous
- ◆ A static grid is generated along the orbit swath. Grid cells dimensions are different depending on instruments and channels. Square cells around the sub satellite track definition is as follows:
  - 5Km × 5Km for 157GHZ of MADRAS
  - 10Km × 10Km for 18/23/36 and 89GHz MADRAS, and SAPHIR
  - 40Km × 40km for SCARAB
- ◆ The brightness temperature for MADRAS and SAPHIR and radiances for SCARAB of samples falling within a grid cell are used to obtain interpolated brightness temperature data or radiance data at the cell centre. The estimated brightness temperature or radiance will be provided along with cell-centre geo-location, time and other relevant parameters and flags
- ◆ Radiometric corrections are applied
- ◆ It should be noted that the swath of the various sensors are different, about 1700 Km for SAPHIR and MADRAS and 2200 Km SCARAB , combined information will not cover exactly the full grid
- ◆ Grids are defined using a theoretical orbit (cycle: 7 days), and are calculated for all the life time of mission for 7 consecutive days using nominal orbit definition. Grid is generated for a swath of 2400 km and appropriate cells relevant for different payloads are populated. Subsequently the grid is fixed.

#### Definition of 5Km grid

- ◆ The 5km based swath grid is composed of 7674 rows (one orbit length: TBD) and 481 columns. (values TBC) The rows are set perpendicular to the orbit trace according to spherical trigonometric conventions. The 481 elements in a row are 5km apart, covering a swath of about 2400 Km.
- ◆ Phasing of the grid : TBD
- ◆ Each element of the grid specifies a grid centre. Each grid centre will be identified by longitude/latitude information and orbit reference number in the 7 days cycle (TBD)
- ◆ Brightness temperatures and radiances will be computed for each grid centre as long as grid centres are included in instrument swaths
- ◆ The following figures illustrate the grid definition for two different situations. Since the across track grid size  $g_{ac}$  are maintained at 5km (for 5km grid), and the perpendicular condition is satisfied, the along track  $g_{al}$  may deviate slightly from 5km.

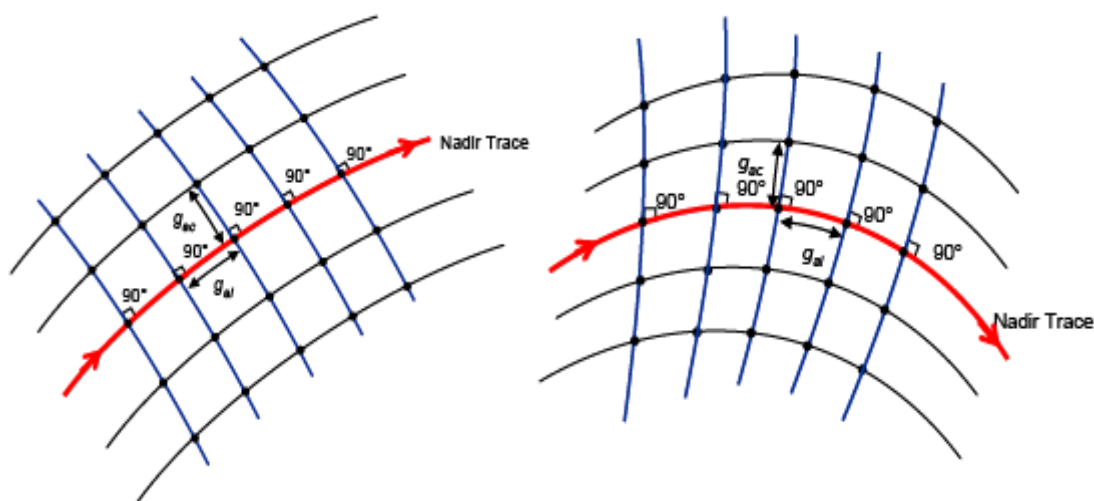

Figure 6.3-1: Grid reference for two different cases

Definition of 10Km cells and 40km cells of the grid

- ◆ The 10km sized cells and 40km sized cells are generated accumulating cells as follow :

One 10 km grid cell is made up of four 5 km grid cells. The 10 km based swath grid is composed of 3837 rows (one orbit length: TBD) and 241 columns (values TBC) the rows are set perpendicular to the orbit trace according to spherical trigonometric conventions. The 241 elements in a row are 10km apart, covering a swath of about 2400 Km.

One 40 km grid cell is composed of sixty four 5 km grid cells. The 40 km based swath grid is composed of 960 rows (one orbit length: TBD) and 61 columns (values TBC). The rows are set perpendicular to the orbit trace according to spherical trigonometric conventions. The 61 elements in a row are 40km apart, covering a swath of about 2400 Km.

- ◆ Centres of the 10km and 40km cells shall be calculated and are not coincident with the centres of 5km cells

### 6.3.1 MADRAS content in L1B

- ◆ Interpolation methods using samples generated in L1A2 products will be used to calculate the estimated brightness temperature of one cell
- ◆ Incidence angle will also be provided.

C.N.E.S./ I.S.R.O.	<b>Megha-Tropiques</b>	Réf. TRO-0-ST-1610-CNES Ed: 3 Date: Jan17th 2013 Issue : 4 Page : 68
--------------------	------------------------	---

### **6.3.1.1 Content of MADRAS L1B file**

The MADRAS level 1B format details are described in the following document .  
See excel document [ProductDefinition\\_MADRAS\\_L1A-1-1-2-3-B\\_HDFMGTSstructure\\_13rev2.xls](#)

### **6.3.2 SAPHIR content in L1B product**

- ⇒ Estimated brightness temperature of cells will be calculated by interpolation method using SAPHIR L1A samples.

#### **6.3.2.1 Content of SAPHIR L1B file**

The SAPHIRlevel 1B format details are described in the following document .  
See excel document [ProductDefinition\\_SAPHIR\\_L1A-1-1-2-3-B\\_HDFMGTSstructure\\_13rev2.xls](#)

### **6.3.3 SCARAB content of L1B product**

Estimated radiance of 40Km sized cells is computed by interpolation method using SCARAB L1A samples.

For each cell, information such as viewing angle, relative azimuth angle will be provided.

#### **6.3.3.1 Content of Scarab L1B file**

The SCARABlevel 1B format details are described in the following document .  
See excel document [ProductDefinition\\_SCARAB\\_L1A-1-1-2-3-B\\_HDFMGTSstructure\\_13rev2.xls](#)

## 7 INTERFACE WITH MISSION CENTER

Level 1 data will be made available at mission centre every day using ftp server for CNES and ICARE and removed after 7 days.

## 8 LEVEL 1 ARCHIVE

Only Level 1 orbit wise products (standard) will be archived in the mission centre ISSDC in Bangalore.

All level1 processing chain will be configuration controlled at ISRO, and all requested information to identify the configuration will be incorporated in level 1 data.

L1 products will be archived on a day basis.

The volume of standard level 1 standard products is:

Sensor Name	Volume of Orbit-wise product in Mega Bytes(MB)			
	L1A	L1A2	L1A3	L1B
MADRAS	67.96	20.34	20.34	10x10Grid
				5x5grid
				Total(MADRAS)
SAPHIR	19.66	14.11	17.14	27.84
SCARAB	2.11	2.11	18.15	2.35
Total by orbit	89.73	36,56	55.63	106,97
Total by day (14 orbits)	1256.2	511.84	778.82	1497,58

Table 8-1: Volume of standard level 1